



PAW GmbH & Co.KG
Böcklerstr. 11, D-31789 Hameln, Germany
Phone: +49 (0)5151-9856-0, Fax: +49 (0)5151-9856-98
E-Mail: info@paw.eu, Web: www.paw.eu



English

Commissioning and Operation Instructions

Controller MCom



Contents

	General safety instructions	3
1	General information.....	4
	1.1 About these instructions	4
	1.2 Designated use	4
	1.3 CE declaration.....	4
2	Safety instructions	5
3	Product description.....	6
4	Installation and maintenance	7
	4.1 Maintenance.....	7
	4.2 Deinstallation and disposal.....	7
5	Operation.....	8
	5.1 User interface	8
	5.2 Operating buttons.....	8
6	Commissioning.....	9
	6.1 Overview inputs and outputs	9
	6.2 Connection and settings.....	10
	6.3 Function test.....	14
7	Setup menu	15
	7.1 Overview parameters	15
	7.2 Overview of the current control state.....	19
	7.3 Display of the current differential pressure and flow rate	20
	7.4 Display of the current heat flow	20
	7.5 System status.....	21
	7.6 Communication	22
	7.7 Set the nominal values	24
	7.8 Change the basic settings	25
	7.9 User code	27
	7.10 Set the heating circuit type and the heating circuit application	28
	7.11 Set the pump	29
	7.12 Set the mixing valve	29
	7.13 Set the heating circuit number.....	29
	7.14 Manual operation of the actuator / pump.....	30
	7.15 Offset.....	30
	7.16 Update status	30
	7.17 Version	31
	7.18 Serial number	31
8	Status messages and error correction.....	32
	8.1 LED status display.....	32
	8.2 Status messages.....	32
	8.3 Blocking protection	35
	8.4 Radiator balancing	35
	8.5 Priorities of the internal program processing.....	35
	8.6 Pump.....	37
9	Technical data	39
	Copyright.....	40

General safety instructions

- This document is part of the product.
- Install and use the device only after having read and understood this document.
- Keep this document in a safe place during the entire service life of the device. Pass this document on to subsequent owners and users of the device.
- Please observe all safety instructions. Please contact an additional expert if uncertainties occur.
- The measures described in this document may only be carried out by qualified technical professionals. Exception: End customers are allowed to operate the controller if they have been trained by a technical professional beforehand.
- The heating circuit and the main body can be damaged by improper operation.
- The device must not be connected to the power supply if:
 - the housing is open or damaged.
 - cables are damaged.
- Factory labels and markings must never be modified, removed or rendered unreadable.
- Observe the prescribed operating conditions.
For more information, see the section *Technical data*.
- This device is not intended for:
 - Children
 - Persons with restricted physical, sensory or mental capacities
 - Persons without sufficient experience or knowledge unless they are instructed in the use of the device, and initially supervised, by a person responsible for their safety.

1 General information

1.1 About these instructions

This manual contains all the information required by a technical professional to set up and operate the controller.

This document describes the installation, the commissioning and the functioning of the MCom controller. For other components of the heating installation, such as the pump groups, the distribution manifold, the storage tank and the expansion tanks, please observe the instructions of the respective manufacturer.

These instructions are exclusively designed for authorised skilled personnel who:

- have the knowledge of relevant terminology and the skills necessary to set up and operate heating installations.
- have the necessary professional training, knowledge and experience as well as the knowledge of the relevant regulations, in order to evaluate the following work and to detect potential dangers:
 - Installation of electrical devices
 - Assembly and connection of data lines
 - Assembly and connection of power supply lines.

1.2 Designated use

The MCom controller is an electronic sensor, regulation and control device for the setting and balancing of heating installations. The maintenance-free controller has been designed specifically for domestic use and may only be integrated in or added to PAW heating circuits of the type HeatBloC MC.

Only use PAW accessories with the controller.



Caution

Personal injury and damage to property!

The device has been conceived as regulation and control device for the operation of the installation, an application in safety-related systems is not allowed. If low temperatures are f. ex. premixed for radiant panel heating systems via mixed heating circuits, the 230 volts of the pump must be led via a safety temperature limiter.

1.3 CE declaration

The MCom controller is CE labelled according to the regulations of the following directives:

- 2006/95/EG - Low Voltage Directive
- 2004/108/EG - EMC Directive

The compliance with the EMC limit values has been checked according to DIN EN 60730-1, residential sector.

The Declaration of Conformity is available upon request, please contact the manufacturer.

2 Safety instructions



Warning

Risk to life and limb due to electric shock!

- Prior to commencing electrical work on the controller, pull the mains plug!
 - Immediately disconnect the device from the power supply if it can no longer be operated safely, f. ex. in the case of visible damage.
 - Disconnect the device from the power supply before opening the housing.
 - All work on the open device may only be carried out by professional personnel.
-



Caution

Personal injury and damage to property!

The device has been conceived as regulation and control device for the operation of the installation, an application in safety-related systems is not allowed. If low temperatures are f. ex. premixed for radiant panel heating systems via mixed heating circuits, the 230 volts of the pump must be led via a safety temperature limiter.



Note

- The controller and the optionally available communication set are delivered with power supply units which are equipped with mains plugs and thus with plug connections with switch-off device.
 - If the relevant local regulations prescribe the installation of separators for fixed electrical systems, these separators must be integrated at least in the 230 V connecting lines of the pumps.
 - Only use PAW accessories with the controller.
 - Damaged lines must be replaced through original connecting lines.
-

3 Product description

The controller regulates the revolution speed of the pump in such a way that an adjustable **differential pressure** is maintained **between the flow and the return**. The balancing of the distribution manifold is also guaranteed for distribution manifolds with differential pressure (without hydraulic separator).

The balancing of the distribution manifold permits:

- a low return temperature
- an energy-saving operation of the pumps
- a security of supply without overpressure at the thermostatic valves (avoids whistling noises).

In some heating circuits not only the differential pressure is controlled but also the temperature. For this purpose the actuator (24 V) has to be connected to the controller MCom. Then the controller MCom regulates the temperature to a constant level.

	Pump	Actuator
	On / Off Revolution speed	Controller (voltage)
MC41 Direct heating circuit	230 V switched by an external heating circuit controller Speed control via MCom	—
MC42 3-way mixing valve		External heating circuit controller (230 V)
MC43 3-way mixing valve with bypass		MCom (24 V), constant flow temperature
MC44 3-way mixing valve with bypass		External heating circuit controller (230 V)
MC45 4-way mixing valve		External heating circuit controller (230 V)
MC46 Boiler charging set with 3-way mixing valve		MCom (24 V), constant return temperature

To establish the power supply, up to 8 controllers are interconnected with bus lines.

The bus lines are included in the scope of delivery.

For the function of a MC system, **one** connection set (wall power supply, item no. 1398700) is necessary.

The wall power supply is only included in the scope of delivery of the HeatBloC MC46.

The controller MCom can be connected via the bus line to the optional communication set. With the communication set, a visualisation and configuration via a free app are possible.

The HeatBloC MC43 is suited and approved for the connection to the SmartHome central system "wibutler". For the connection to the wibutler system it is mandatory to install a communication set (item no. 1398730) and a wibutler EnOcean dongle (item no. 1398735), both not included in delivery.

4 Installation and maintenance

The controller is mounted above the heating circuit insulation of the HeatBloCs MC and is equipped with pre-assembled lines.

Please observe the following instructions for an operationally reliable functioning of your installation:

- The location of installation must be dry, load-carrying, frost-proof and protected against ultraviolet radiation.
- The controller must not be installed outside.
- During operation, the access to the control and safety equipment must be guaranteed at all time!

4.1 Maintenance

The controller MCom is maintenance free and must not be opened.

Only clean the controller housing with a dry cloth and without cleaning agents.

The heating installation should be checked once a month. Leakages, pressure drops and air can thus be detected at an early stage and the efficiency of the system can be guaranteed.

4.2 Deinstallation and disposal



Danger

Risk of death by electrocution!

- The housing of the wall power supply must not be opened.
It must be replaced through PAW accessories.
-

Dispose of the electrical and electronic components of the installation according to the European Waste Electronic and Electrical Equipment Directive. For further information, please contact the local authorities responsible for the disposal.

5 Operation

This section contains general information on the operation of the controller.

5.1 User interface



No.	Element
①	Display
②	Rotary knob

Front view of the controller

5.2 Operating buttons

The controller is operated via the rotary knob as follows:

Turn to the right	<ul style="list-style-type: none"> • Scrolls down in the menu • Increases a setting value by 1 level
Turn to the left	<ul style="list-style-type: none"> • Scrolls up in the menu • Decreases a setting value by 1 level
Briefly pressing (< 1 second)	<ul style="list-style-type: none"> • Confirms the selection or entry
Long pressing (> 2 seconds)	<ul style="list-style-type: none"> • Goes back to the main menu • Deletes minimal / maximum measured values in the respective menu selection



Note

We recommend to write down all the settings that you have changed. For this purpose, use the table in chapter [7.1 Overview parameters](#).

6 Commissioning

6.1 Overview inputs and outputs

No.	Marking	Description				
X1		Only used with MC43 and MC46: PAW actuator type NR24-SR-318 -,+ = 24 V dc, I _{max} = 250 mA Y = 0-10 V, I _{max} = 2 mA U = 0-10 V, > 40 kOhm	X1	X2	X3	X4
X2		↓, -: Control of the pump -, ↑: Return signal of the pump I _{max} = 10 mA PWM: ~10 V Analogue: 0-10 V	X5	X6.1	X6.2	
X3		Temperature sensor return Pt1000				
X4		Temperature sensor flow Pt1000				
X5		Differential pressure sensor (Δp) T: 0-5 V IN dP/V: 0-5 V IN -: GND +: 5 Vdc Functional earth: flat plug 6.3				
X6.1 X6.2	24Vdc RS485	Supply voltage: 24 Vdc Communication bus: RS485, Modbus				

6.2 Connection and settings



Note

It is preferable not to plug the power supply unit of the optional communication set in the socket yet. Wait until you have adjusted all controllers. Thus, you don't have to scan the Modbus once again.

1. Connect the sensors according to the hydraulics instructions of the heating circuits (see page 12/13).
2. Establish the power supply.
3. The controller is preset when it is delivered. When starting the controller, the following parameters must be verified successively. Check if these parameters correspond to the components used. Confirm the selection with OK or select another option by turning the rotary knob.

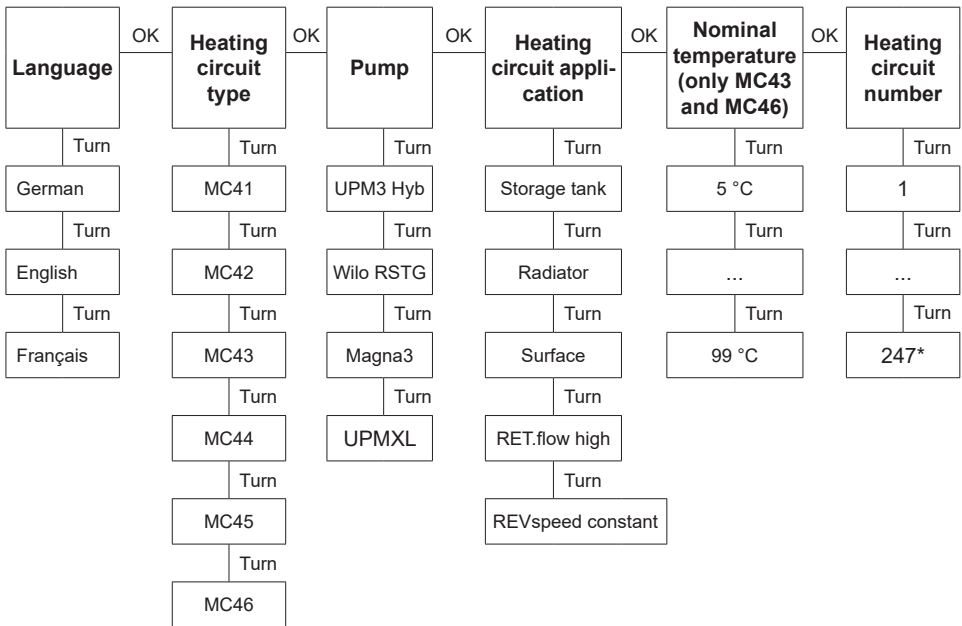

Each heating circuit number has to be assigned once only.

Please note: The control is active in the background even without confirmation of the parameters and uses the parameters preset at the factory as regulation basis (see table on the next page).

If no confirmation is given within the time slot, the controller uses the parameters preset at the factory or the last parameters set as regulation basis.

* For the use in a building control system, a heating circuit number between 1 and 247 can be set. When starting the communication set, only the heating circuit numbers 1 to 8 are called up.

4. In the menu `Basic settings`, set the date and the clock time at the controllers. If you have the optional communication set, it is sufficient to set these adjustments at the heating circuit number 1. The clock time is communicated automatically to all the other controllers by the mini PC of the communication set within 5 minutes.
5. Connect the communication set to the power supply.

Factory settings:

Heating circuit type (HCM type)	Description	Heating circuit application (HCM application)	Nominal differential pressure Δp	Nominal temperature
MC41	Direct heating circuit	Radiator heating	100 mbars	/
MC42	Mixed heating circuit, 3-way mixing valve; the actuator is controlled by the boiler regulation	Radiator heating	100 mbars	/
MC43	Mixed heating circuit; 3-way mixing valve with bypass; the actuator is controlled by the MCom controller	Radiant panel heating	150 mbars	30 °C
MC44	Mixed heating circuit; 3-way mixing valve with bypass; the actuator is controlled by the boiler regulation	Radiant panel heating	150 mbars	/
MC45	Mixed heating circuit; 4-way mixing valve; the actuator is controlled by the boiler regulation	Radiant panel heating	150 mbars	/
MC46	Boiler charging set with 3-way mixing valve; the actuator is controlled by the MCom controller	Return flow temperature maintenance	50 mbars	55 °C

Example of a connection scheme: automatic, dynamic balancing of the distribution manifold

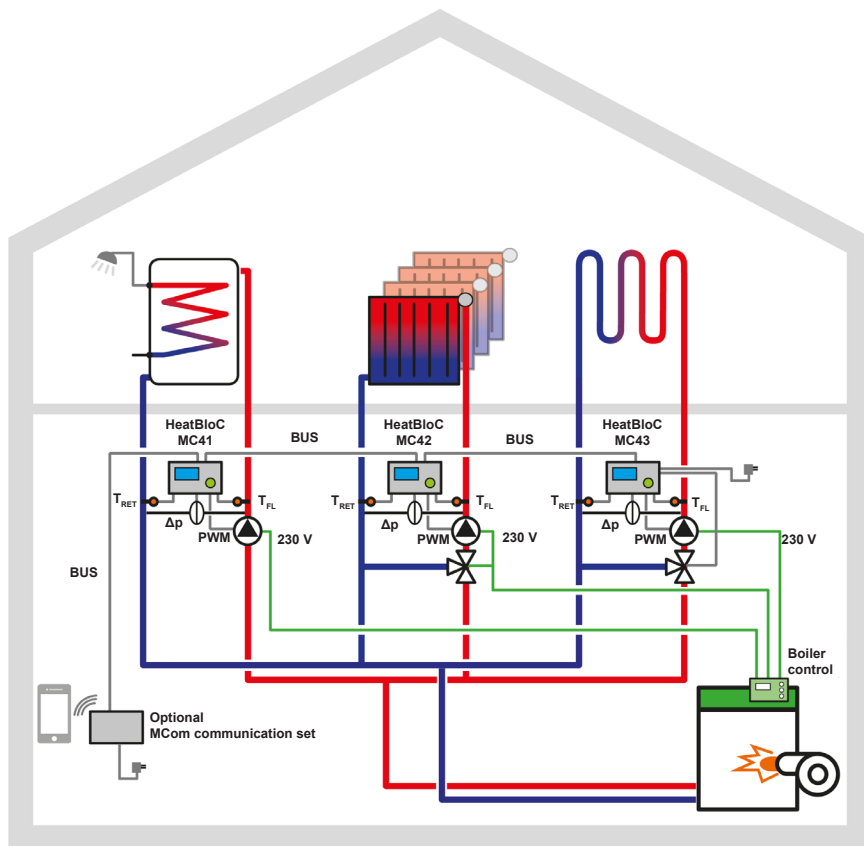

Heating circuit type	MC41	MC42	MC43
Heating circuit application	Storage tank charging	Radiator heating	Radiant panel heating
Heating circuit number	1	2	3

Example 2 of a connection scheme: return flow temperature maintenance

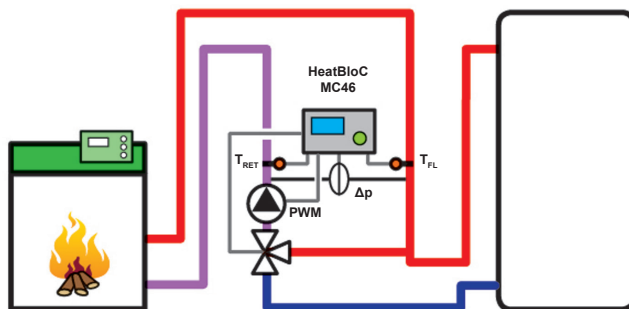

Heating circuit type	MC46
Heating circuit application	Return flow temperature maintenance
Heating circuit number	1

Example 3 of a connection scheme: balancing without a distribution manifold

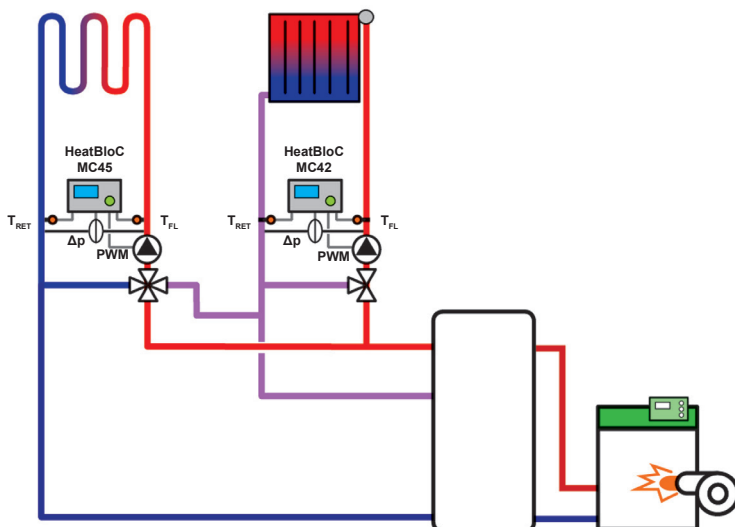

Heating circuit type	MC45	MC42
Heating circuit application	Radiant panel heating	Radiator heating
Heating circuit number	1	2

6.3 Function test

1. Check if all sensors, pumps and valves are connected.
2. Check if the parameters of the installation correspond to the components used.
Please observe the indications of chapter [7 Settings menu](#).
 - Right heating circuit type (HCM type)
 - Right heating circuit application (HCM application: Storage tank charging, radiator heating, radiant panel heating, return flow temperature maintenance, revolution speed constant)



Attention

Damage to property!

Setting inappropriate parameters can cause dysfunctions and damage to the installation.

3. Check in the manual mode if the outputs are active and if the pumps run.
4. Check via the displays of the inputs if the sensors are connected and if they deliver logical values.
 - Is a differential pressure generated if the pump runs?
 - Is the flow temperature during heating operation higher than the return temperature?
5. Set the controller to automatic operation mode.
6. Hand the installation including the technical documentation over to the installation operator.
Make sure that you receive a confirmation attesting the proper commissioning and functioning of the installation.

7 Settings menu

Chapter 7.1 shows an overview of the menu system. As of chapter 7.2 the single menu items are described in detail.

7.1 Overview parameters

The following scheme shows the structure of the settings menu. Certain menu items are hidden if it is not possible to set any values because of the settings chosen.

Display	Factory setting	Change to	
MCxx <> --W	XXXmbar >< --W	/	/
MCxx XX°C <>		/	/
0 mbar 0 l/h			
	Δp	/	/
	Min. / Max.		
	\dot{V}		
	Min. / Max.		
	Back		
\dot{Q} kW	Sum \dot{Q}		
	Back		
System status			
	(Nominal value)		
	(Actual value return signal)		
	/ %		
	(Nominal value)		
	(Actual value return signal)		
	/ %		
	T FL / nominal		
	FL: / RET:		
	FL min. / max.		
	RET min. / max.		
	Back		
	T FL	/	/
	T RET	/	/
	Δp	/	/
	Pump	/	/
	Mixing valve	/	/
	MCom	/	/

Display		Factory setting	Change to
	Modbus	/	/
	wibutler	/	/
	Back		
Communication			
	Switch off PC		
	Restart PC		
	Scan Modbus		
	Reinstall FW		
	Powerline		
		on	
		off	
		Back	
	WLAN		
		Name	MCom
		Channel	11
		Reset password	
		Back	
	LAN		
	Back		
Nominal values			
	Δp		
		0-600 mbars	depends on HCM applic.
	PWM		
		0-100 %	50 %
	temperature		
		5-99 °C	depends on HCM applic.
	Back		
Basic settings			
	Language		German
		German	
		English	
		French	
		Back	
	Date		
		DD.MM.YY	
	Clock time		
		hh:mm:ss	
	CET/CEST		Automatic

Display		Factory setting	Change to
	Automatic Manual operation Back		
	Illumination	Automatic	
	Automatic Always on Always off Back		
	Luminosity		
	1-8	2	
	Contrast		
	1-8	7	
	Mode	MCom	
	MCom wibutler Back		
	Back		
User code	0000	9856	0000
HCM type	MC41 MC42 MC43 MC44 MC45 MC46 Back		
HCM applic.	Storage tank charging Radiator heating Radiant panel heating Return flow temp.maint. Revol. speed constant Back		
Pump	GF UPM3 Hyb Wilo YP RSTG GF Magna3 GF UPMXL Back		

Display		Factory setting	Change to
Mixing valve	Type		
	Internal		
	External		
	Back		
	Direction		
	Right		
	Links		
	Back		
HC no.	0-247	1	
Auto / Manual	Mixing valve		Automatic
	Automatic		
	Manual operation		
	Back		
	Mixing valve %		
	Pump		Automatic
	Automatic		
	Manual operation		
	Back		
	Pump PWM / analogue		
	Pump %		
	Back		
Offset	T FL	0	
	T RET	0	
	Δp		
	Back		
Update status			
Version			
MCom S/N	Field 1-2		
	Field 3-4		
	Back		

7.2 Overview of the current control state

Shows an overview of the current control state depending on the nominal values of pressure, PWM control and mixing valve control.

7.2.1 Control state of nominal pressure or PWM control

The display changes automatically.

Example:

M C 4 3
< > 1 1 W

1 5 0 m b a r
> < 1 1 W

First line: Information on HCM type (here: MC43) and the nominal pressure (here: 150 mbars)

Second line: Shows the actual state depending on the nominal value as well as the current performance of the pump (only Grundfos UPM3).
Notice! The controller works in the background to balance deviations.

For HCM applications: storage tank charging, radiator heating, radiant panel heating, return flow temperature maintenance:

Display	Description
< > or > <	The system is optimally balanced.
- or +	> 10 % deviation (too low / too high) from the nominal pressure
SensFail	Differential pressure sensor defective.
PumpFail	PWM pump cable defective.

For HCM application: Revolution speed constant:

Display	Description
< > or > <	The system is optimally balanced.

7.2.2 Control state: nominal value of the mixing valve control

√ In the menu `Mixing valve > Internal` is set (only MC43 and MC46).

Example:

M C 4 3	3 0 C
< >	

First line: Information on HCM type (here: MC43) and the nominal value of the mixing valve control in °C (here: 30 °C).

Second line: Shows the actual state depending on the nominal value.
Notice! The controller works in the background to balance deviations.

Display	Description
< > or > <	The system is optimally balanced.
- or +	5 % deviation (too low / too high) from the nominal value
-- or ++	10 % deviation (too low / too high) from the nominal value
--- or +++	> 15 % deviation (too low / too high) from the nominal value
Error	Temperature sensor defective.

7.3 Display of the current differential pressure and flow rate

√ You are in the menu `0mbar 0 l/h`.

It displays the currently measured differential pressure and flow rate.

In the submenu, the recorded minimal and maximum values of the differential pressure and the flow rate are displayed. The values can be deleted by pressing the rotary knob for at least 2 seconds.

The flow rate will only be displayed, if a flow rate signal is available (f. ex. the pump return signal of Grundfos UPM3 Hybrid).

No adjustments possible. If necessary, the differential pressure can be adjusted in the technician mode in the menu `Nominal values > Δp`.

7.4 Display of the current heat flow

√ You are in the menu \dot{Q} .

It displays the currently measured heat flow.

The heat flow will only be displayed, if a flow rate signal is available (f. ex. the pump return signal of Grundfos UPM3 Hybrid).

In the submenu, the sum of the heat flow is displayed. The values can be deleted by pressing the rotary knob for at least 2 seconds.

No adjustments possible.

7.5 System status

Displays the different states of the system.

To read the status message, please refer to chapter [8.2 Status messages](#).

7.5.1 Display of the nominal value of the pump control

√ You are in the menu  ← /  → .

It displays the nominal value of the pump control and the actual value of the pump return signal.

In the submenu, the recorded minimal and maximum values of the pump return signal are displayed. The values can be deleted by pressing the rotary knob for at least 2 seconds.

 ← = Nominal value of the pump control

 → = Actual value of the pump return signal

No adjustments possible.

7.5.2 Display of the nominal value of the mixing valve control

√ You are in the menu  ← /  → .

√ In the menu `Mixing valve > Internal` is set (only MC43 and MC46).

It displays the nominal value of the mixing valve control and the actual value of the mixing valve return signal.

In the submenu, the recorded minimal and maximum values of the mixing valve return signal are displayed. The values can be deleted by pressing the rotary knob for at least 2 seconds.

 ← = Nominal value of the mixing valve control

 → = Actual value of the mixing valve return signal

No adjustments possible.

7.5.3 Display of the nominal value of the temperature

√ You are in the menu `TFL: / Nom:` or `TRET: / NOM:`

√ In the menu `Mixing valve > Internal` is set (only MC43 and MC46).

It displays the nominal value of the temperature and the currently measured temperature.

No adjustments possible.

7.5.4 Display of the current flow / return temperature

√ You are in the menu `FL: / RET:`

It displays the currently measured flow and return temperature.

In the submenu, the recorded minimal and maximum values of the flow and return temperature are displayed. The values can be deleted by pressing the rotary knob for at least 2 seconds.

No adjustments possible.

7.6 Communication

- √ You have installed the optionally available communication set.
- √ You are in the menu `Communication`.



Note

For information on connection data see the instructions of the communication set.

In this menu, you can control the mini PC of the communication set.

It is imperative to read the system status „Modbus“ before using this function (see chapter [8.2 Status messages](#)). The system status for „Modbus“ must display „OK“, in order that the controller can actuate the mini PC of the communication set. If the system status displays an error here, use another MCom controller to actuate the mini PC. Check the system status for „Modbus“ beforehand.

Select one of the following options:

- Switch off PC
- Restart PC
- Scan Modbus
- Reinstall the firmware
- WLAN
- Switch on/off Powerline
- LAN

Select the desired option. Press the rotary knob until the arrows on the display have completely run through.

Switch off PC:

Via this command, the mini PC of the communication set and the entire system are switched off. The message „PC is switched off“ appears. Press the rotary knob for at least 2 seconds to go to the main menu.

Restart PC:

Via this command, the mini PC of the communication set is restarted.

Scan Modbus:

Via this command, the mini PC of the communication set reads out the heating circuit numbers. During the Modbus Scan, the MCom controller works properly in the background.

When starting the Modbus scan, the displays of all MCom controllers show the set heating circuit number and the communication state. The background lightning is blinking.

As soon as the communication set identifies a MCom controller, the background lightning of the corresponding MCom controller is constantly illuminated.

After the scan has been finished, all identified MCom controllers show the former displayed data. Non-identified MCom controllers are blinking for another 5 minutes.

To go to the main menu during the Modbus scan, press the rotary knob for at least 2 seconds. The Modbus scan is continuing and the background lightning is blinking until the MCom controller has been identified or until the scan has been finished.

Reinstall the firmware (New FW Install):

Via this command, the mini PC reinstalls the firmware on all controllers.

WLAN:

The WLAN submenu is described in the chapters 7.6.1 ff.

Powerline:

The Powerline adapter (item no. 1398736) enables to use the MCom app in the entire building. This is necessary for radiator balancing via MCom. With activated Powerline function the WLAN of the controller MCom and the communication set is deactivated.

LAN:

By pressing the control button the LAN IP of the communication set is displayed, if it's connected to a router via LAN cable.

7.6.1 Change the WLAN name

√ You are in the menu `Basic settings > WLAN > Name`.

In this menu, you can change the WLAN name if several communication sets are installed within reach. Assign each WLAN name only once in order to guarantee a clear allocation and to avoid mutual interference of the communication sets.

With the setting „Off“, the WLAN can be switched off.

With activated Powerline function the WLAN configuration is deactivated.

Change the WLAN name at the heating circuit number 1. The name is communicated automatically to all the other controllers by the mini PC of the communication set within 5 minutes.

The following settings are available:

- Off
- MCom
- MCom1 to MCom5

Factory setting: MCom

**Note**

To change the WLAN settings of the communication set the system status for "Modbus" has to display "OK" (menu: `System status > Modbus`). If the system status of the controller displays an error, use another MCom controller with the system status "OK" to change the settings.

7.6.2 Change the WLAN transmission channel

√ You are in the menu `Basic settings > WLAN > Name`.

In this menu you can change the transmission channel of the WLAN. This is necessary if other wireless networks within reach cause problems.

Change the WLAN transmission channel at the heating circuit number 1. The transmission channel is communicated automatically to all the other controllers by the mini PC of the communication set within 5 minutes.

With activated Powerline function the WLAN configuration is deactivated.

Adjustment range: 1-15

Factory setting: 11

**Note**

To change the WLAN settings of the communication set the system status for "Modbus" has to display "OK" (menu: `System status > Modbus`). If the system status of the controller displays an error, use another MCom controller with the system status "OK" to change the settings.

7.6.3. Reset the WLAN password

√ You are in the menu `Basic settings > WLAN > Reset password`.

In this menu, the WLAN password can be reset.

Press the rotary knob until the arrows on the display have completely run through. The WLAN password is reset to the factory settings.

With activated Powerline function the WLAN configuration is deactivated.

Factory setting: paw31789

**Note**

To change the WLAN settings of the communication set the system status for "Modbus" has to display "OK" (menu: `System status > Modbus`). If the system status of the controller displays an error, use another MCom controller with the system status "OK" to change the settings.

7.7 Set the nominal values

√ You are in the menu `Nominal values`.

For the setting of nominal values depending on the heating circuit type chosen and the heating circuit application.

Adjustable nominal values:

- **Differential pressure** (only for heating circuit applications: storage tank charging, radiator heating, radiant panel heating and return flow temperature maintenance)
 - Adjustment range: 0-600 mbars
 - Factory setting:
 - Radiator heating: 100 mbars
 - Radiant panel heating: 150 mbars
 - Storage tank charging: 50 mbars
 - Return flow temperature maintenance: 50 mbars
- **PWM signal** (only for heating circuit application: revolution speed constant)
 - Adjustment range: 0-100 %
 - Factory setting: 50 %
- **Temperature** (only for mixing valve type internal)
 - Adjustment range: 5-99 °C
 - Factory setting: 30 °C (for heating circuit application return flow temperature maintenance: 55 °C)

**Note**

In the `wibutler mode`, the wibutler system controls the nominal values. The nominal values set at the MCom controller are only used if there is no communication with the wibutler system.

7.8 Change the basic settings

√ You are in the menu `Basic settings`.

Adjustment of the following parameters:

- Language
- Date
- Clock time
- Daylight saving time / standard time
- Illumination
- Luminosity
- Contrast
- MCom / wibutler mode

7.8.1 Set the language

√ You are in the menu `Basic settings`. > `Language`

The following languages are available:

- German
- English
- French

1. Press the rotary knob. The selection appears.
2. Turn the rotary knob to select a language.
3. Press the rotary knob to confirm the language chosen.

Factory setting: German

7.8.2 Set the date

√ You are in the menu `Basic settings`. > `Date`

1. Press the rotary knob. The selection appears in the format DD.MM.YY. The number corresponding to the day is blinking.
2. Turn the rotary knob to set the day.
3. Press the rotary knob to confirm the day.
4. The number corresponding to the month is blinking.
5. Repeat the steps 2 and 3 to set the month and the year.
6. `yes` is blinking.
7. If the date is correct, press the rotary knob to confirm the date. If the date is not correct, turn the rotary knob to the right. `no` is blinking. Press the rotary knob to cancel the modifications.



Note

If you have the optional communication set, it is sufficient to set these adjustments at the heating circuit number 1. The clock time is communicated automatically to all the other controllers by the mini PC of the communication set within 5 minutes.

7.8.3 Set the clock time

√ You are in the menu `Basic settings.` > `Clock time`

1. Press the rotary knob. The selection appears in the format hh:mm:ss. The number corresponding to the hour is blinking.
2. Turn the rotary knob to set the hour.
3. Press the rotary knob to confirm the hour.
4. The number corresponding to the minutes is blinking.
5. Repeat the steps 2 and 3 to set the minutes and the seconds.
6. `yes` is blinking.
7. If the clock time is correct, press the rotary knob to confirm the clock time. If the clock time is not correct, turn the rotary knob to the right. `no` is blinking. Press the rotary knob to cancel the modifications.



Note

If you have the optional communication set, it is sufficient to set these adjustments at the heating circuit number 1. The clock time is communicated automatically to all the other controllers by the mini PC of the communication set within 5 minutes.

7.8.4 Change to daylight saving time / standard time

√ You are in the menu `Basic settings.` > `CET/CEST`

The following settings are available to change to daylight saving time or to standard time:

- Automatic:
automatic change to daylight saving time / standard time is activated
- Manual operation:
automatic change to daylight saving time / standard time is not activated

Factory setting: Automatic

7.8.5 Set the background lighting

√ You are in the menu `Basic settings.` > `Illumination`

The following settings are available for the background lighting:

- Automatic:
The background lighting turns on during the operation of the controller and turns off 5 minutes after the last entry.
- Always on:
Increases the energy consumption and reduces the service life of the display.
- Always off

1. Press the rotary knob. The selection appears.
2. Turn the rotary knob to select the setting.
3. Press the rotary knob to confirm the setting.

Factory setting: Automatic

7.8.6 Set the luminosity

√ You are in the menu `Basic settings. > luminos.`

1. Press the rotary knob. The selection appears.
2. Turn the rotary knob to select the setting.
3. Press the rotary knob to confirm the setting.

Please note: The higher the luminosity value is set, the higher the energy consumption gets.

Factory setting: 2

7.8.7 Set the contrast

√ You are in the menu `Basic settings. > Contrast.`

1. Press the rotary knob. The selection appears.
2. Turn the rotary knob to select the setting.
3. Press the rotary knob to confirm the setting.

Factory setting: 7

7.8.8 MCom / wibutler mode

√ You are in the menu `Basic settings. > Mode.`

The system which controls the heating circuits can be set here.

- MCom: The controller operates in an autonomous manner with its own settings.
- wibutler: The controller is connected to a wibutler system. The nominal values are defined by the wibutler system. The settings of the MCom controller are only used in the case of a failure of the wibutler system.
Please observe the separate instructions regarding the wibutler system.

Factory setting: MCom



Attention

Damage to property!

Only the heating circuit type MC43 is suited for the use in a wibutler system. Improper settings of the MC system may result in damage to property.

7.9 User code

√ You are in the menu `User code.`

The technician mode has been set at the factory.

We recommend to switch to the display mode after having worked on the controller to avoid changing parameters.

Switch to the technician mode to set the heating circuit type, the heating circuit application and other settings that depend on the heating circuit type.

Code	Description
0000	Display mode
9856	Technician mode

7.10 Set the heating circuit type and the heating circuit application

- √ The technician mode is activated.
- √ You are in the menu HCM type / HCM application.

Each heating circuit type can be combined with each heating circuit application.

Setting options heating circuit type:

Heating circuit type (HCM type)	Description
MC41	Direct heating circuit
MC42	Mixed heating circuit, 3-way mixing valve; the actuator is controlled by the boiler regulation
MC43	Mixed heating circuit; 3-way mixing valve with bypass; the actuator is controlled by the MCom controller
MC44	Mixed heating circuit, 3-way mixing valve with bypass; the actuator is controlled by the boiler regulation
MC45	Mixed heating circuit, 4-way mixing valve; the actuator is controlled by the boiler regulation
MC46	Boiler charging set with 3-way mixing valve; the actuator is controlled by the MCom controller

Setting options heating circuit application:

- Storage tank charging
- Radiator
- Radiant panel heating
- Return flow temperature maintenance
- Revolution speed constant

Factory settings:

Heating circuit type (HCM type)	Heating circuit application (HCM application)	Nominal differential pressure Δp	Nominal temperature
MC41	Radiator heating	100 mbars	/
MC42	Radiator heating	100 mbars	/
MC43	Radiant panel heating	150 mbars	30 °C
MC44	Radiant panel heating	150 mbars	/
MC45	Radiant panel heating	150 mbars	/
MC46	Return flow temperature maintenance	50 mbars	55 °C



Note

The heating circuit application storage "Revolution speed constant" operates with a constant PWM signal. Factory setting: 50 %.

7.11 Set the pump

- √ The technician mode is activated.
- √ You are in the menu `Pump`.

In this menu, the pump integrated in the heating circuit can be set.

Setting options:

- Grundfos UPM3 Hybrid
- Wilo-Yonos PARA RSTG
- Grundfos Magna3
- Grundfos UPMXL

7.12 Set the mixing valve

- √ The technician mode is activated.
- √ You are in the menu `Mixing valve`.

In this menu, the actuator integrated in the heating circuit can be set.

Setting options:

- **External:** The actuator is controlled by an external heating circuit controller.
- **Internal:** The actuator is controlled by the MCom controller.
- **Right/Left:** after changing the flow line set here the new direction of rotation. Do not forget to change the scale of the actuator.

7.13 Set the heating circuit number

- √ The technician mode is activated.
- √ You are in the menu `HC no.`

The heating circuit number must be determined.

1. Number the heating circuits from left to right with 1 to 8.
2. Connect the optional communication set to the power supply.
When starting the communication set, only the heating circuit numbers 1 to 8 are called up.

To unplug the controller from the network, put the corresponding heating circuit number to 0. Thus, the communication interface of the controller is deactivated, but the functionality of the parameterised control is maintained.



Note

For the use in a building control system, a heating circuit number between 1 and 247 can be set. The set number is both heating circuit number and Modbus ID.

7.14 Manual operation of the actuator / pump

- √ The technician mode is activated.
- √ You are in the menu `Auto / Manual`.

In this menu, the manual mode can be set for the actuator and the pump.

Setting options:

- Automatic
- Manual operation

Factory setting for both: Automatic

Manual operation actuator:

√ In the menu `Mixing valve > Internal` is set (only MC43 and MC46).
 Select the manual operation in `Mixing valve > Manual operation`.
 Here, you can define the mixing valve position in %.

Manual operation pump:

Select the manual operation in `Pump > Manual operation`.
 You can adjust the pump signal here:

- PWM or analogue
- 0% - 100%

7.15 Offset

- √ The technician mode is activated.
- √ You are in the menu `Offset`.

This function serves exclusively for problem handling after having contacted the PAW customer service.

In this menu you can change the measured value of the sensors by a constant value.

Adjustable values:

- **Flow temperature T FL**
 Adjustment range: -25.0 °C to +25.0 °C, in steps of 0.1 °C
- **Return temperature T RET**
 Adjustment range: -25.0 °C to +25.0 °C, in steps of 0.1 °C
- **Differential pressure**
 Adjustment range: -200 mbars to 200 mbars, in steps of 1 mbar

7.16 Update status

It displays the download progress of the update.

Once the download has been completed, the update is imported and the rotary knob is illuminated in orange.

During this time, no operation is possible.



Note

It is imperative not to disconnect the controller from the power supply during an update!

7.17 Version

It displays the software version, f. ex. `version 1.26.000`. In the submenu, the creation time and the creation date of the software are displayed.

7.18 Serial number

√ You are in the menu `MCom S/N`.

It displays the serial number of the MCom controller.

Example: Display of the serial number "C000001234":

1:	C0000		3:	-----
2:	01234		4:	-----

8 Status messages and error correction



Warning

Risk of death by electrocution!

- Immediately disconnect the heating circuit from the power supply if it can no longer be operated safely, f. ex. in the case of visible damage.
- Immediately inform your specialised craftsman!



Note

The controller is a quality product which has been conceived for numerous years of continuous operation. Please observe the following aspects:

- The cause of an error is often not the controller but one of the connected components.
- The following notes about fault localisation indicate the most frequent causes of error.
- Send the controller in only after having contacted the PAW customer service.

8.1 LED status display

The colour of the rotary knob indicates the status of the heating circuit. Please refer to the following table for error tracing.

LED display rotary knob	Description	Solution
Steady green light	The system is error free.	—
Green blinking	The PAW MCom app or the wibutler system requires an identification.	—
Red blinking	The system contains an error.	Open the system status in the menu and compare the status message with section 8.2 Status messages .
Steady yellow light	The controller is partially or entirely in manual mode.	If necessary, set the automatic mode at the controller.
Steady orange light	An update is in progress. Do <u>not</u> disconnect the controller from the power supply.	Wait until the update is completed.

8.2 Status messages

If the rotary knob is blinking red, potential errors are displayed in the menu `system status`.

Turn the rotary knob in the menu `system status` to get to the status messages.

Display:

The first line describes the connected component.

The second line describes the status:

- OK if the system does not contain an error or
- short error message (see table)

Component	Error	Description	Solution
Blocking protection	no error	The blocking protection function is executed automatically once a day and takes several minutes. Please observe the indications of chapter <u>8.3 Blocking protection</u> .	During this time, an operation of the controller is not possible. Wait until the blocking protection is completed.
Balancing in progress	no error	The balancing of the radiators is started manually by the specialist using the MCom app.	During this time, an operation of the controller is not possible. Wait until the radiator balancing is completed.
T _{FL}	Closed	Short circuit at sensor T _{FL} For MC43: The MCom controller regulates the actuator to 10% flow admixing (= 25% mixing valve control)	Check the sensor at T _{FL} and replace it if necessary
	Broken	Interruption at sensor T _{FL} For MC43: The MCom controller regulates the actuator to 10% flow admixing (= 25% mixing valve control)	Check the connection at sensor T _{FL} and replace it if necessary
T _{RET}	Closed	Short circuit at sensor T _{RET} For MC46: The MCom controller regulates the actuator to 100% return admixing.	Check the sensor at T _{RET} and replace it if necessary
	Broken	Interruption at sensor T _{RET} For MC46: The MCom controller regulates the actuator to 100% return admixing.	Check the connection at sensor T _{RET} and replace it if necessary
Δp	HighVolt	Overvoltage at differential pressure sensor. The MCom controller actuates the pump with a PWM signal of 100 %.	Check the differential pressure sensor and replace it if necessary
	LowVolt	Undervoltage at differential pressure sensor. The MCom controller actuates the pump with a PWM signal of 100 %.	Check the differential pressure sensor and replace it if necessary
Pump (only for pumps with return signal)	Error 85	Electrical fault	<ul style="list-style-type: none"> Consult the pump manual. Disconnect the pump from the power supply and establish it again Maintain the pump.
	Error 90	Pump blocked	
	Broken	No pump return signal	Check the PWM pump cable.
	Stop OK	The pump has been switched off by the wibutler or controller MCom (f. ex. in manual operation).	The system contains no error.
Mixing valve	HighVolt	Overvoltage at the actuator return signal	Check the connection and replace the actuator if necessary







Component	Error	Description	Solution
MCom	No Clock	Hardware error	Please contact the manufacturer.
	SPI	Hardware error	Please contact the manufacturer.
Modbus	No Comm.	No communication via Modbus. The rotary knob is illuminated in green.	If the communication set is not installed, there is no error. If the communication set has been installed: <ul style="list-style-type: none"> • Check the assigned heating circuit number • Check the communication line to the communication set • Verify if the communication set is activated (the red LED at the communication set is illuminated). • Scan Modbus via the menu Communication • Restart the communication set
wibutler	Verify	No communication with the communication set. The rotary knob is illuminated in green.	<ul style="list-style-type: none"> • Check the assigned heating circuit number • Check the communication line to the communication set • Verify if the communication set is activated (the red LED at the communication set is illuminated). • Scan Modbus via the menu Communication • Restart the communication set
wibutler	No Comm.	No communication with the wibutler for at least 6 minutes.	<ul style="list-style-type: none"> • Verify if the wibutler is activated • Verify if the wibutler contains errors • Verify if the wibutler is within the reach of the MCom WLAN • Verify if the MCom system has been installed in the wibutler • Restart the communication set
wibutler	NoDongle	No Dongle connected to the communication set	<ul style="list-style-type: none"> • Connect Dongle • Check the dongle: green LED is illuminated = power supply established yellow LED is illuminated = radio transmission of data
wibutler	TeachIn	The connection to the wibutler is establishing.	<ul style="list-style-type: none"> • Complete the teach-in process at the wibutler • Verify if the wibutler is activated • Verify if the wibutler is within the reach of the MCom WLAN • Wait and then check the mode again after 10 minutes. • Restart the communication set and the MC system

8.3 Blocking protection

The `blocking protection` function is executed automatically once a day and takes several minutes.

The controller with heating circuit number 1 starts the function `blocking protection` at 12:05. The other controllers start in order of their heating circuit ID shifted in time by 5 minutes.

Order:

1.  = 0 %
2.  = closing (140 sec)
3.  = 100 %
4.  = 0 %
5.  = opening (140 sec)
6.  = closing (140 sec)
7. Previous state (automatic / manual operation)

8.4 Radiator balancing

Using the pump Grundfos UPM3 Hybrid or Grundfos UPMXL, the optional communication set and the free MCom app you can balance the radiators of the entire building.

Conditions are an existing two pipe heating and radiators with restrictor.

The balancing of the radiators is started via the MCom app. During the balancing all controllers display "Balancing in progress". At the same time there is no entry possible, the internal mixing valve (24 V) closes and only one of the pump runs with high revolution speed. After finishing the balancing via the app or after 15 minutes without any entry, the controllers MCom change to normal control.

8.5 Priorities of the internal program processing

To facilitate error tracking the following chapters show the order of the internal program processing.

8.5.1 Mixing valve control

√ In the menu `Mixing valve` > Internal is set (standard for MC43 and MC46).

Priority	Description	Effect
1	Radiator balancing is active	<ul style="list-style-type: none"> Mixing valve control 0%
2	Manual operation is activated.	<ul style="list-style-type: none"> Actuator does not work. LED is illuminated in yellow.
3	The wibutler calculation results that at the moment no additional energy is needed in the heating circuit (f. ex. room sensors).	<ul style="list-style-type: none"> Pump is set to 0% speed and remains switched off. Mixing valve control 0% <p>The wibutler triggers this function every 5 minutes. Otherwise the controller MCom uses the last values received from the wibutler to control the system.</p>
4	Fault at temperature sensor T_{FL}	<ul style="list-style-type: none"> Emergency operation: Mixing valve control 25% (except MC46)
	Fault at temperature sensor T_{RET}	<ul style="list-style-type: none"> only MC46: Emergency operation: Mixing valve control 100%
5	Current differential pressure < 10 mbars	<ul style="list-style-type: none"> Mixing valve control 0% (except MC46)
		<ul style="list-style-type: none"> only MC46: Mixing valve control 100%

8.5.2 Pump control

Priority	Description	Effect
1	Radiator balancing is active	<ul style="list-style-type: none"> Active circuit: Control to constant differential pressure of 580 mbars. Passive circuit: Pump is set to 0% speed and remains switched off.
2	Manual operation is activated.	<ul style="list-style-type: none"> Pump is set to a constant revolution speed (0-100%). LED is illuminated in yellow.
3	The wibutler calculation results that at the moment no additional energy is needed in the heating circuit (f. ex. room sensors).	<ul style="list-style-type: none"> Pump is set to 0% speed and remains switched off. Mixing valve control 0% <p>The wibutler triggers this function every 5 minutes. Otherwise the controller MCom uses the last values received from the wibutler to control the system.</p>
4	Fault at the differential pressure sensor	<ul style="list-style-type: none"> Pump is set to 100%.

8.6 Pump

The pumps Wilo-Yonos PARA RSTG, Grundfos UPM3 Hybrid and Grundfos UPMXL have been correctly adjusted at the factory. The pump Grundfos Magna3 has to be set on site. In the case of a breakdown of the control (no PWM signal), the pumps Wilo-Yonos PARA RSTG, Grundfos UPM3 Hybrid and Grundfos UPMXL run at maximum rotation speed, the pump Grundfos Magna3 runs at minimum rotation speed.

To assure a proper functioning of the heating circuit, the pump must be set as follows:

8.6.1 Wilo-Yonos PARA RSTG

The rotary knob of the pump must be set to the following symbol. The LED ring is illuminated in orange. Please observe the separate instructions of the pump!



8.6.2 Grundfos UPM3 Hybrid

The following code must appear on the pump display. The code can be verified by briefly pressing the push button. Please observe the separate instructions of the pump!

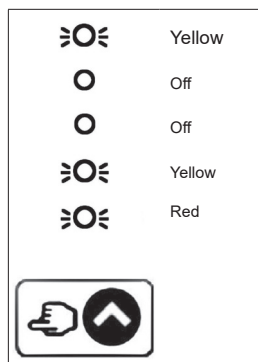

8.6.3 Grundfos Magna3

The configuration is carried out via the pump display. Please observe the separate instructions of the pump!

I) Set the control type

1. You are in the menu *Settings*.
2. Select *Control mode* and confirm by pressing OK.
3. Select *Constant curve* and confirm by pressing OK.
4. Press the Home button to return to the main menu.

II) Set the nominal value

1. You are in the menu *Settings*.
2. Select *Nominal value* and confirm by pressing OK.
3. Press OK.
4. Set *100%* as nominal value and confirm by pressing OK.
5. Press the Home button to return to the main menu.

III) Set the analogue input

1. You are in the menu *Assist*.
2. Select *Analogue input* setup and confirm by pressing OK.
3. Continue to scroll.
4. Select *External nominal value adjustment* and continue to scroll.
5. Select *0-10 V* as signal type and continue to scroll.
6. Check the displayed summary and confirm by pressing OK.

IV) Set the setpoint influence

1. You are in the menu *Settings*.
2. Select *Nominal value adjustment* and confirm by pressing OK.
3. Select *External setpoint function* and confirm by pressing OK.
4. Select *Linear with MIN* and confirm by pressing OK.
5. Press the Home button to return to the main menu.

9 Technical data

Inputs / outputs	
Connection X1	1 x continuous mixing valve „NR24-SR-318“ -,+ = 24 V dc, I _{max} = 250 mA Y = 0-10 V, I _{max} = 2 mA U = 0-10 V, > 40 kOhm
Connection X2	Pump: Control and return signal I _{max} = 10 mA PWM: ~10 V Analogue: 0-10 V
Connection X3	T _{RET} : 1 x Pt1000, Molex C-Grid/SL
Connection X4	T _{FL} : 1 x Pt1000, Molex C-Grid/SL
Connection X5	1 x sensor DPS 0-0.6 T: 0-5 V IN dP/V: 0-5 V IN -: GND +: 5 Vdc Functional earth: flat plug 6.3
Connection X6	2 x bus line RJ12 (6P6C), Power supply, communication 24 Vdc, RS485
Display	LCD with background lighting, multicoloured status display at the operating element
Protection class	IP 21 (when installed)
Protection class	III (Attention: If a DPS sensor is connected to X5, a functional earth is connected to the hydraulics)
Ambient temperature	0 ... +50 °C, in the case of free wall mounting
Degree of pollution	2
Software class	A
Mode of action	Type 1.Y
Physical values	
Dimensions L x W x H	100 x 70 x 60 mm
Weight	130 g
Accessories	
Compulsory	Power supply: Specifically adapted power supply unit, Input: 240V~50 Hz, 0.7 A, Euro plug Output: 24 V dc, 1 A, RJ12, RS485 terminator L/D x W x H: 33 x 79 x 54 mm, Weight: 208 g
Optional	Communication set

Copyright

PAW GmbH & Co. KG shall be the sole owner of the copyright and any and all present and future industrial property rights in the MCom software or in their technical content. You may not copy, alter, decompile, disassemble, decode, create derivative works from, remove any parts of or modify the software in any other way.

When the software was developed, third-party software was used in some cases.

- a) Atmel AVR1316
Copyright (c) 2008, Atmel Corporation
All rights reserved.

Redistribution and use in source and binary forms, with or without modification, are permitted provided that the following conditions are met:

1. Redistributions of source code must retain the above copyright notice, this list of conditions and the following disclaimer.
2. Redistributions in binary form must reproduce the above copyright notice, this list of conditions and the following disclaimer in the documentation and/or other materials provided with the distribution.
3. The name of ATMEL may not be used to endorse or promote products derived from this software without specific prior written permission.

THIS SOFTWARE IS PROVIDED BY ATMEL „AS IS“ AND ANY EXPRESS OR IMPLIED WARRANTIES, INCLUDING, BUT NOT LIMITED TO, THE IMPLIED WARRANTIES OF MERCHANTABILITY AND FITNESS FOR A PARTICULAR PURPOSE ARE EXPRESSLY AND SPECIFICALLY DISCLAIMED. IN NO EVENT SHALL ATMEL BE LIABLE FOR ANY DIRECT, INDIRECT, INCIDENTAL, SPECIAL, EXEMPLARY, OR CONSEQUENTIAL DAMAGES (INCLUDING, BUT NOT LIMITED TO, PROCUREMENT OF SUBSTITUTE GOODS OR SERVICES; LOSS OF USE, DATA, OR PROFITS; OR BUSINESS INTERRUPTION) HOWEVER CAUSED AND ON ANY THEORY OF LIABILITY, WHETHER IN CONTRACT, STRICT LIABILITY, OR TORT (INCLUDING NEGLIGENCE OR OTHERWISE) ARISING IN ANY WAY OUT OF THE USE OF THIS SOFTWARE, EVEN IF ADVISED OF THE POSSIBILITY OF SUCH DAMAGE.

- b) MODBUS Slave Library: A portable MODBUS slave for MODBUS ASCII/RTU/TCP.
Copyright (c) 2008 Christian Walter <cwalter@embedded-solutions.at>
All rights reserved.



PAW GmbH & Co.KG
Böcklerstr. 11, D-31789 Hameln, Germany
Phone: +49 (0)5151-9856-0, Fax: +49 (0)5151-9856-98
E-Mail: info@paw.eu, Web: www.paw.eu