



Installation and Operation Instructions

Transfer stations

SolexMidi TW - DN 20

SolexMaxi TW - DN 25

[Hydraulics]



SolexMidi TW



SolexMaxi TW

Table of Contents

1	General Information.....	3
1.1	About these instructions.....	3
1.2	About this product.....	4
1.3	Designated use.....	5
2	Safety instructions.....	6
3	Mounting and installation [specialist].....	8
4	Commissioning [specialist].....	12
4.1	Flushing and filling the secondary circuit.....	14
4.2	Flushing and filling the solar circuit.....	15
4.3	Parameters of the controller SC5.14.....	21
5	Maintenance [specialist].....	22
5.1	Replacement / adjustment of the pressure gauge.....	22
5.2	Maintenance work.....	23
5.3	Draining the solar system.....	24
5.4	Deinstallation.....	24
6	Scope of delivery [specialist].....	25
6.1	Spare parts controller and insulation SolexMidi TW (6095436).....	25
6.2	Spare parts hydraulics SolexMidi TW (6095436).....	27
6.3	Spare parts controller and insulation SolexMaxi TW (6096465).....	29
6.4	Spare parts hydraulics SolexMaxi TW (6096465).....	31
7	Technical data.....	33
7.1	Dimensional drawing SolexMidi TW.....	34
7.2	Dimensional drawing SolexMaxi TW.....	34
7.3	Pressure drop and pump characteristic curves SolexMidi TW.....	35
7.4	Pressure drop and pump characteristic curves SolexMaxi TW.....	35
8	Function of the check valves [Expert].....	36
9	Disposal.....	38
10	Commissioning report.....	39

1 General Information



Carefully read these instructions before installation and commissioning.

Save these instructions in the vicinity of the installation for future reference.

1.1 About these instructions

These instructions describe the functioning, installation, commissioning and operation of the Solex TW transfer stations for charging buffer tanks or domestic hot water tanks.

The chapters called [specialist] are intended for specialists only.

For other components of the solar installation, such as pumps, collectors, storage tanks or expansion tanks, please observe the instructions of the corresponding manufacturer.

DN 20	Item number	Controller SC5.14	max. flow rate	max. collector surface
SolexMidi TW	6095436		1200 l/h	50 m ²

DN 25	Item number	Controller SC5.14	max. flow rate	max. collector surface
SolexMaxi TW	6096465		2000 l/h	100 m ²

1.2 About this product

The station is a premounted group of valves and fittings checked for leakage and used to transfer the heat from the primary circuit (solar circuit) to the secondary circuit (storage tank or domestic hot water circuit).

It contains a preset controller as well as important fittings for the operation of the system:

- Ball valves in the primary circuit (flow and return)
- Piston valves in the secondary circuit (flow and return)
- Check valves to avoid involuntary gravity circulation in the flow and return of the solar circuit, non return valve in the return of the secondary circuit
- Pressure relief valves to prevent inadmissible overpressures of the station
- Pressure gauge for displaying the installation pressure in the primary circuit
- Vent valves to easily vent the primary circuit and the secondary circuit
- Fill and drain valves with caps to flush, fill and drain the primary circuit
- Flow meter (FlowRotor) and temperature sensors for heat quantity balancing (primary)

On the heating side, the installation must be equipped with a **safety group** that can be ordered separately.

The **expansion tank** required for operation must be adapted to the size and the requirements of the installation and must be ordered separately.

The **cap valve** (DN 20: item no. 5302, DN 25: item no. 5301), which is also separately available, allows the expansion tank to be easily mounted and separated from the solar thermal system.

1 General Information

1.3 Designated use

The station may only be used as a transfer station between the solar and the domestic hot water circuit or between the solar and the storage tank circuit in solar thermal systems taking into consideration the technical limit values indicated in these instructions. Due to its design, the station must only be mounted and operated as described in these instructions!

Improper usage excludes any liability claims.

This product complies with the relevant directives and is therefore labelled with the CE mark.

The Declaration of Conformity is available upon request, please contact the manufacturer.

Only use PAW accessories with the product.

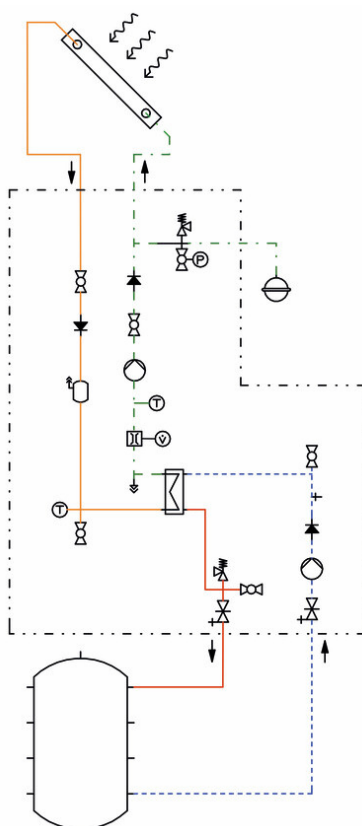

NOTICE

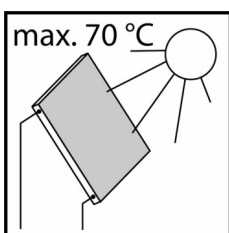

Under the influence of solar radiation, the collectors will heat up considerably. The solar fluid in the solar circuit may heat up to more than 100 °C. Only flush and fill the solar circuit when the collector temperatures are below 70 °C.

2 Safety instructions

The installation and commissioning as well as the connection of electrical components require technical knowledge commensurate with a recognised vocational qualification as a fitter for plumbing, heating and air conditioning technology, or a profession requiring a comparable level of knowledge [specialist].

The following must be observed during installation and commissioning:

- relevant local and national regulations
- accident prevention regulations of the professional association
- instructions and safety instructions mentioned in these instructions

WARNING	
	<p>Danger of scalding due to the escape of hot fluids!</p> <p>With pressure relief valves, there is a risk of scalding due to the escape of vapour or hot fluid.</p> <p>Please ensure for each pressure relief valve that no personal injury or material damage may occur due to possibly escaping medium.</p> <ul style="list-style-type: none"> ▶ Install a discharge line. ▶ Observe the instructions regarding the pressure relief valve. ▶ The pressures for the expansion tank calculated by the plant designer and the operating pressure of the installation must be set.

WARNING	
	<p>Personal injury due to polluted potable water!</p> <p>Heating water contains harmful substances that must not be washed into the domestic hot water circuit.</p> <p>If the station has been used to charge a buffer tank, there is still heating water in the valves and fittings and in the pump of the secondary circuit, even after draining. The heating water can not be completely removed.</p> <ul style="list-style-type: none"> ▶ The station must not be connected to a domestic hot water circuit any more.

2 Safety instructions

CAUTION



Risk of burns!

The valves and fittings and the pumps can become heated up to more than 100 °C during operation.

- ▶ The insulating shell must remain closed during operation.

CAUTION



Personal injury and material damage due to overpressure!

Closing both ball valves in the primary circuit will separate the safety group from the heat exchanger. A rise in temperature in the storage tank may result in high pressures, which may lead to personal injury and material damage!

- ▶ Only close the ball valves for service and maintenance.
- ▶ When closing the ball valves in case of servicing, also put the pumps out of operation and close the ball valves / piston valves of the secondary circuit.

NOTICE

Material damage due to mineral oils!

Mineral oil products cause lasting damage to seals made of EPDM, whereby the sealant properties are lost. We do not assume liability nor provide warranty for damage to property resulting from sealants damaged in this way.

- ▶ It is imperative to prevent the EPDM sealing elements from making contact with substances containing mineral oils.
- ▶ Use a silicone- or polyalkylene-based lubricant free of mineral oil such as Unisilikon L250L and Syntheso Glep 1 from Klüber or a silicone spray.

3 Mounting and installation [specialist]

NOTICE

Material damage due to high temperatures!

Since the solar fluid near the collector can be very hot, the group of fittings must be installed at a sufficient distance from the collector field. It may be necessary to install an intermediate tank in order to protect the expansion tank.

NOTICE

Damage to property!

The installation site must be dry, stable, frost-proof and protected against ultraviolet radiation in order to prevent material damage of the installation. Furthermore, access to the controller and safety equipment must be guaranteed at all times during operation!

NOTICE

Damage to property!

The discharge line of the pressure relief valves must be conducted into heat-resistant collecting containers of corresponding size. This prevents uncontrolled discharging into the environment and enables the circuits to be refilled!

3 Mounting and installation [specialist]

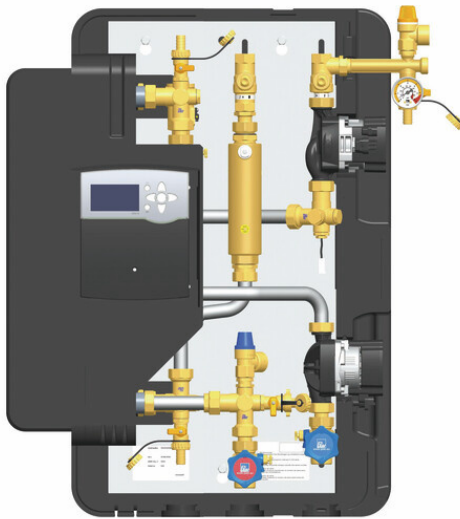

1. A drilling template can be used in order to facilitate the installation. You will find the drilling template on the station.
2. Copy the dimension for the mounting holes to the mounting surface.
3. Drill the holes and insert appropriate wall plugs into the holes.
4. Screw in the screws and let them stick about 4 cm out of the wall.
5. Remove the station from the packaging.
6. Remove the insulating front shell. Hang the station into the wall and tighten the screws.
7. Connect the transfer station to the installation by using the piping:

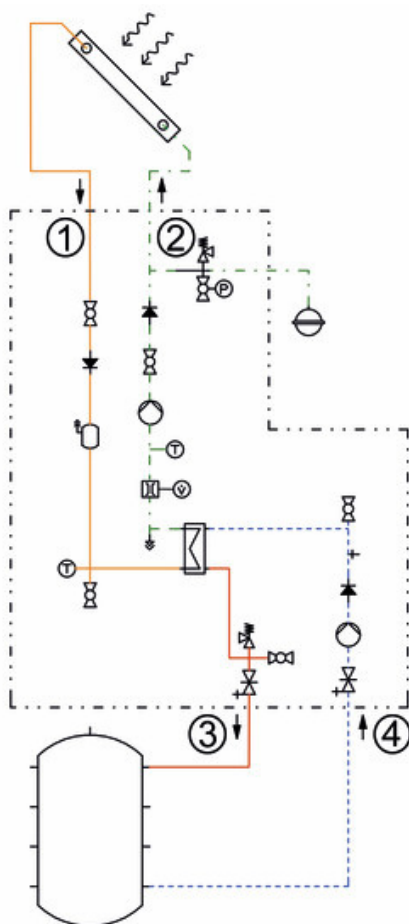

- ① Solar flow from the collector
- ② Solar return to the collector field
- ③ Flow to the storage tank
- ④ Return from the storage tank

The screw connections in the primary circuit of the SolexMidi have $\frac{3}{4}$ " internal threads and in the secondary circuit 1" external threads.

The screw connections in the primary circuit of the SolexMaxi have 1" internal threads and in the secondary circuit $1\frac{1}{4}$ " external threads.

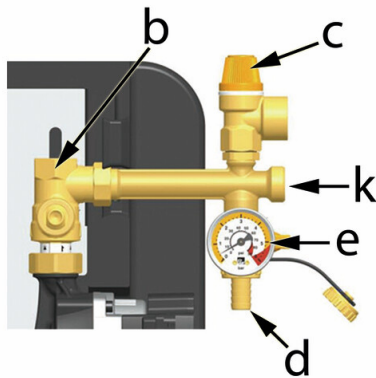

8. Assemble the safety group consisting of safety valve [c], fill valve [d] and pressure gauge [e] on the connection of the return ball valve [b].
9. Connect the pipe for the expansion tank to the position [k] of the safety group and fix the bracket for the expansion tank.

For service work on the expansion tank, we recommend the installation of a cap valve (DN 20: item no. 5302; DN 25: item no. 5301) on the expansion tank.

NOTICE

Note regarding the expansion tank

The expansion tank must not be connected while flushing and filling in order to prevent dirt particles from being flushed in. Please observe the instructions of the manufacturer.

10. Adapt the initial pressure of the expansion tank to the system and connect the expansion tank. Observe the separate instructions for the expansion tank.
11. Check all screw connections and tighten them if necessary.

WARNING



Risk to life and limb due to electric shock!

- ▶ Prior to commencing electrical work on the controller, pull the mains plug!
- ▶ Only after completing all installation work as well as the flushing and filling, the mains plug of the controller can be plugged into a socket. This avoids an unintentional start of the motors.

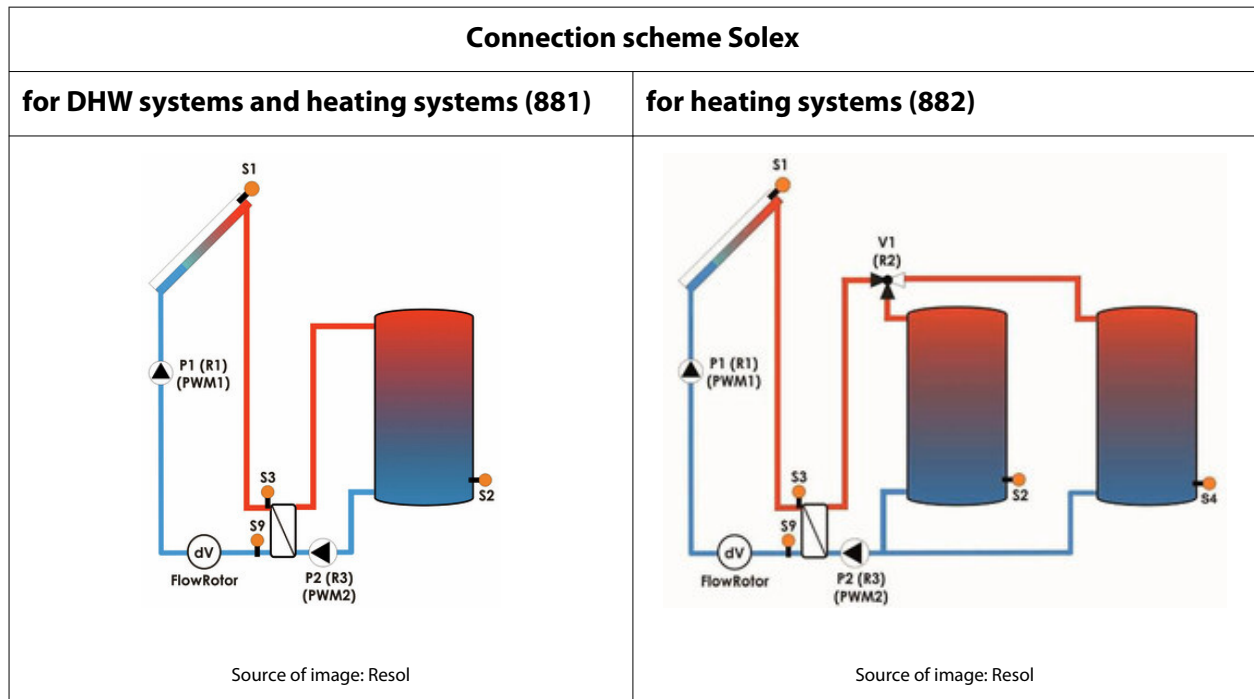

Please observe the separate instructions of the controller SC5.14!

1. Connect the temperature sensors to the controller:

Collector sensor: S1

Collector sensor: S1

Tank bottom: S2

Tank 1 bottom: S2

Integrated: S3, S9, dV (FlowRotor)

Tank 2 bottom: S4 (required on-site,
item no. E13180)



Integrated: S3, S9, dV (FlowRotor)

2. Tighten all union nuts and thread connections.

The assembly of the station is now completed and the station can be put into operation.

4 Commissioning [specialist]

Please observe the following safety instructions regarding the commissioning of the station:

WARNING	
 	<p>Risk of burning and scalding!</p> <p>The valves and fittings may heat up to more than 100 °C. Therefore, do not clean or fill the system when the collectors are hot (intense sunshine). Please note that hot solar fluid leaks from the pressure relief valves in case of too high system pressure!</p> <p>During venting the solar fluid may escape as vapour and result in scalding!</p> <ul style="list-style-type: none"> ▶ Flush and fill the system only when the collector temperatures are below 70 °C.

NOTICE	
<p>Risk of frost!</p> <p>It often happens that solar systems cannot be completely drained after flushing. Thus, there is a risk of frost damage later on when flushing with water. Therefore, only use the solar fluid used later on for flushing and filling the solar installation.</p> <ul style="list-style-type: none"> ▶ Use a water/propylene glycol mixture with max. 50% of propylene glycol as solar fluid. 	

NOTICE	
<p>Note regarding the commissioning sequence</p> <p>Flush and fill in the following order:</p> <ol style="list-style-type: none"> 1. Flush the storage tank (to remove scale residues). 2. Fill the secondary circuit. 3. Vent the heat exchanger via the vent plug / safety valve. 4. Flush and fill the solar circuit of the heat exchanger. 5. Flush and fill the collector field. 6. Flush and fill the (entire) solar circuit <p>This avoids that dirt particles are washed into the heat exchanger or the FlowRotor and guarantees that possibly absorbed heat can be dissipated.</p>	



NOTICE

Note regarding the expansion tank

The expansion tank must not be connected while flushing and filling in order to prevent dirt particles from being flushed in. Please observe the instructions of the manufacturer.

4.1 Flushing and filling the secondary circuit

Depending on the application, the secondary circuit is filled (charging of a domestic hot water tank) via the valves at the domestic hot water tank or (charging of a buffer tank) via the valves of the heating installation. Make sure that only potable water is used in the first case mentioned. In the second case mentioned, only heating water treated according to VDI 2035 / Ö-Norm H5195-1 must be used.

To avoid that dirt particles are washed into the heat exchanger, shut the piston valves of the station and flush out the dirt particles present in the tank before the first commissioning.

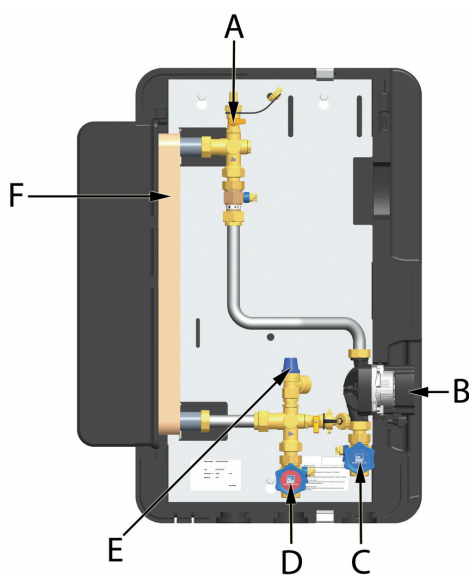

Secondary circuit

1. Open the piston valves [C|D].
2. Vent the secondary circuit by operating the fill and drain valve [A].

Make sure that no water enters the electrical components.

3. Fill the secondary circuit via the valves at the domestic hot water tank or at the heating system.
4. Vent the station during commissioning on the fill and drain valve [A], to remove any air that may still be present in the heat exchanger.

4.2 Flushing and filling the solar circuit

The fill and drain valves required to flush and fill the installation are integrated in the transfer station. Make sure that dirt particles that may be present in the system are not flushed into the heat exchanger and into the expansion tank. To do so, it may be necessary to disconnect the expansion tank during flushing and filling and to use only flushing and filling stations that are equipped with suitable microfilters.

The solar circuit is flushed in the normal direction of flow. Therefore, make sure that the solar circuit pump does not switch on.

Ball valve with integrated flow check valve

(normal flow direction in the figure: downwards)

position 0°

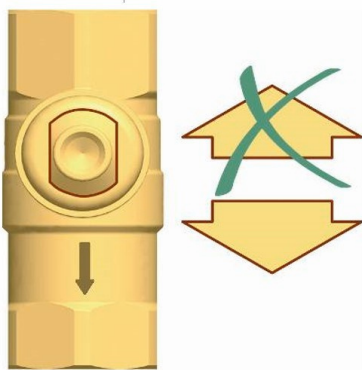

Check valve is operating,
flow only in flow direction.

position 45°

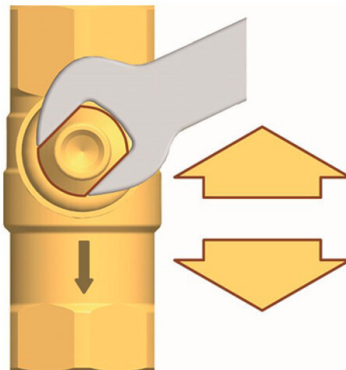

Check valve not operating,
flow in both directions.

position 90°

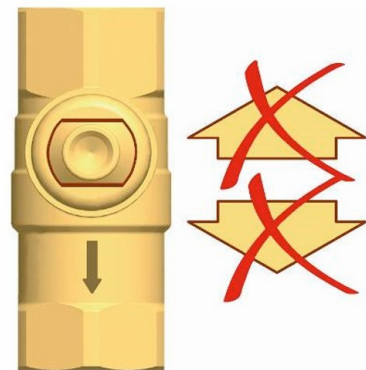

Ball valve closed,
no flow.

Functions of the fill and drain valve within the safety group

Position

Function



Position "closed" (station in operation):

Fill and flush circuit is closed. Pressure gauge indicates system pressure.



Position "open" (fill and flush processes):

Fill and flush circuit is open. Pressure gauge indicates pressure.

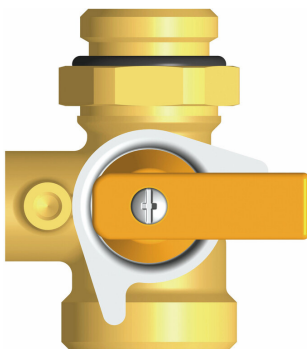

Position "maintenance" (maintenance work):

Fill and flush circuit is closed. Pressure gauge indicates, after removal of cap, no pressure.

Attention: Remove stop bolt before changing the position!

Airstop

The Airstop (vent valve with manual bleeder) is used to vent the solar system. To ensure a perfect venting of the solar circuit, the flow velocity must be at least 0.3 m/s in the flow line.

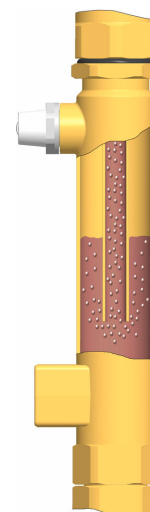

Pipe diameter [mm]		Flow rate at 0.3 m/s	
∅ outside	∅ inside	l/h	l/min
15	13	~ 143	~ 2.4
18	16	~ 217	~ 3.6
22	20	~ 339	~ 5.7
28	25	~ 530	~ 8.8

WARNING



Danger of scalding due to escaping vapour!

The escaping medium can have a temperature of more than 100 °C and cause scalding.

- ▶ Carefully open the vent plug and close it again, as soon as medium escapes.

The air separated from the solar fluid is collected in the upper part of the airstop and can be released at the vent plug.

Venting the solar installation after commissioning

At the beginning, vent the solar installation daily by means of the vent plug [j] and then weekly or monthly, depending on the vented air quantity. Thus, an optimum operation of the solar installation is ensured. Check the system pressure after venting and increase it to the prescribed operating pressure, if necessary.

Flushing and filling

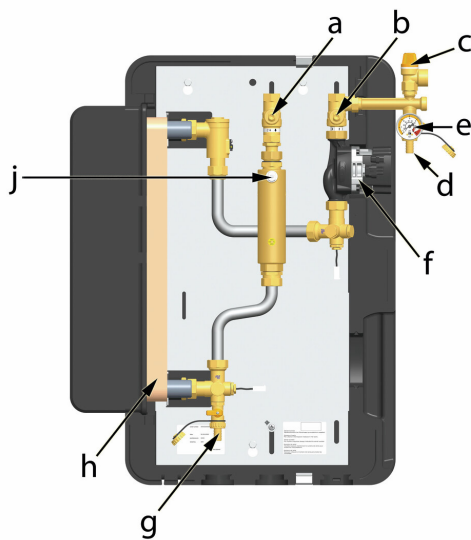

Primary circuit

1. Switch off the pump of the solar circuit.
2. Disconnect the expansion tank from the solar system. This prevents dirt particles still present in the pipes from being flushed into the expansion tank.

Observe the separate instructions for the expansion tank!

3. The return ball valve [b] must be closed (90° position)

4. Connect the flush and fill station:

- pressure hose to the fill valve [d]

- flush hose to the drain valve [g].

5. Open the fill and drain valves [d/g], see section **Functions of the fill and drain valve within the safety group**, and put the flush and fill station into operation.
6. To vent the pump stroke, open and close the return ball valve [b] during flushing.
7. Flush the solar circuit until the solar fluid exits without bubbles.

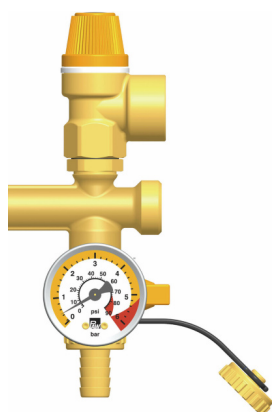

Consider the pressure relief valve (6 bars)!

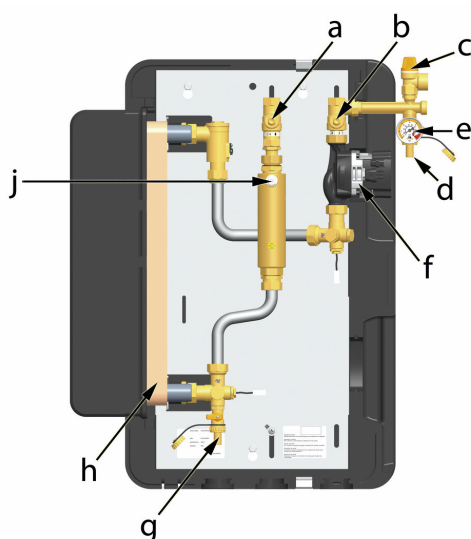

8. Close the drain valve [g] with the filling pump running and increase the system pressure to approx. 5 bars. The system pressure can be read on the pressure gauge [e].
9. Close the fill valve [d], see section **Functions of the fill and drain valve within the safety group** and switch off the pump of the flush and fill station.
10. Check the pressure gauge to see whether the system pressure reduces and eliminate leaks where necessary.
11. Reduce the pressure on the drain valve [g] to the system-specific pressure, if necessary.
12. Connect the expansion tank to the solar circuit and set the operating pressure of the solar installation by means of the flush and fill station (for the required operating pressure, see instructions of the expansion tank).
13. Close the fill and drain valves [d|g], see section **Functions of the fill and drain valve within the safety group**.
14. Turn the ball valve [b] in position 0°.

WARNING



Risk to life and limb due to electric shock!

- ▶ Check whether the sensors and pumps have been connected to the controller and the controller housing is closed.
- Only under these circumstances, the mains plug of the controller can be plugged into a socket.

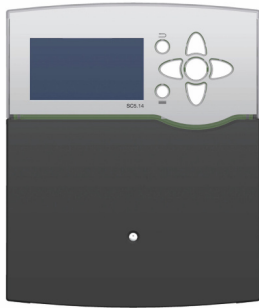

SC5.14

15. Connect the controller to the mains and set the solar circuit pump in manual mode to ON as described in the controller manual.
16. Allow the solar circuit pump to run at the maximum rotation speed level for at least 15 minutes.

In the meantime, vent the solar system several times at the vent plug [j] of the airstop until the solar fluid exits without forming bubbles.

17. If necessary, increase the system pressure to the operating pressure.



18. Remove the hoses of the flush and fill station and screw the sealing caps on the fill and drain valves.

The closure caps are only for protection against contamination. They are not designed for high system pressures. Their tightness is ensured by the closed ball valves.

19. Mount the insulating front shell.
20. Set the automatic mode on the controller (see controller manual).

The commissioning of the solar installation is now completed. Please fill in completely the commissioning log.

4.3 Parameters of the controller SC5.14

The parameters for the sensors and pumps are preset in the controller. If another system is selected and saved, the parameters are reset to the factory settings. In this case, the parameters must be modified in the menu. A proper functioning of the installation is thus ensured. You will find a detailed description of the operation of the controller in the separate controller manual.

Preset system (scheme 881) Solex

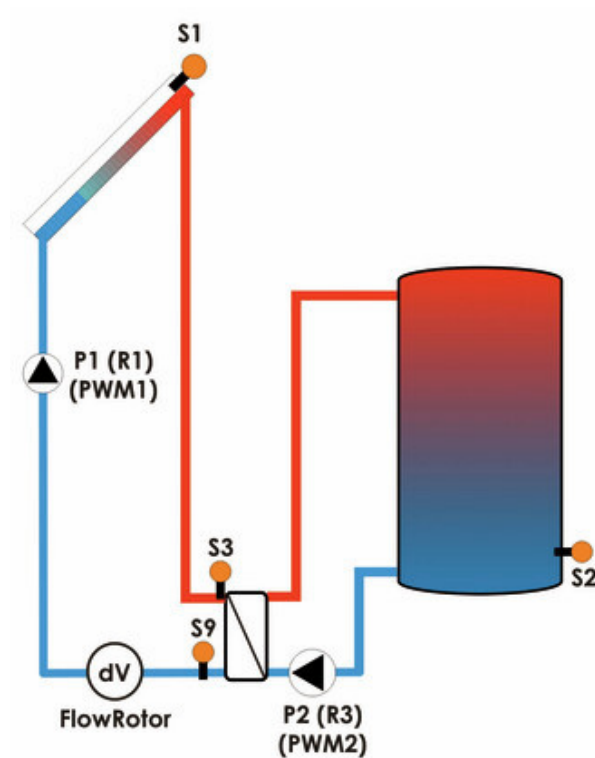

5 Maintenance [specialist]

WARNING	
	<p>Risk of burning and scalding!</p> <p>The valves and fittings and the solar fluid can have temperatures of more than 100 °C. The solar fluid may escape as vapour and result in scalding.</p> <ul style="list-style-type: none"> ▶ Perform maintenance work only when the collector temperatures are below 50 °C. ▶ Wait until the solar fluid has cooled down to at least 50 °C.

5.1 Replacement / adjustment of the pressure gauge

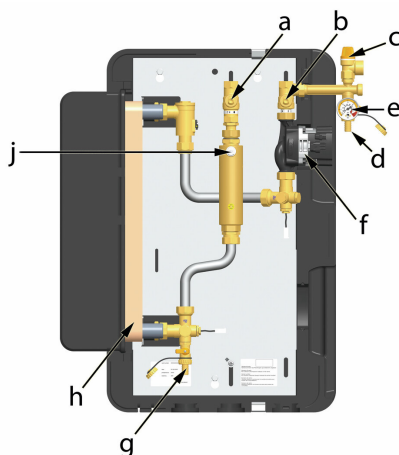

1. Switch off the controller and secure it against being switched on again.
2. Make sure that the valve [d] is closed with a cap.
3. Turn the valve [d] in position "maintenance" by removing the stop screw, see chapter 4.2.
4. **Replacement of the pressure gauge:**

Dismount the pressure gauge [e]. It can happen that a small amount of fluid leaks out (valve content). After that, exchange the pressure gauge.

Adjustment of the pressure gauge:

Loosen the counter nut and turn the pressure gauge (from completely screwed in to max. 360°) anti-clockwise. After that, secure it with the counter nut.

5. Turn the valve [d] again in position "closed" (see chapter 4.2). During this, mount the stop screw.
6. Check the pressure gauge [e] for tightness. Also, check the system pressure and increase it to the prescribed operating pressure, if necessary.
7. Vent the installation. Repeat that weekly or monthly, depending on the vented air quantity.

5 Maintenance [specialist]

5.2 Maintenance work

Depressurise the installation for all replacement or service work on the station. This does not apply for the replacement of the pressure gauge.

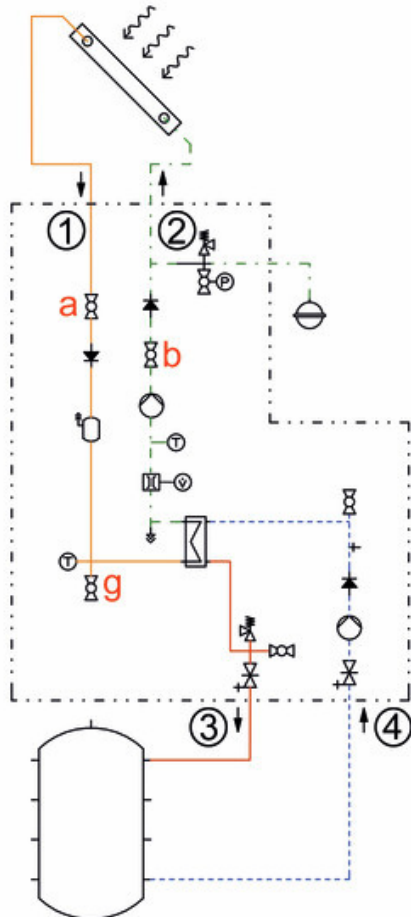

1. Close the ball valves [a|b] and release the solar fluid at the fill and drain valve [g]. Make sure that the solar fluid is collected in a heat-resistant container.
2. Replace the defective part with a new part.
3. Fill the solar circuit, see chapter 4.2.

5.3 Draining the solar system

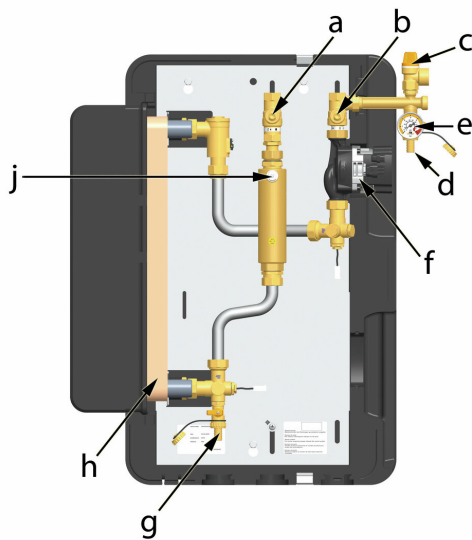

1. Switch off the controller and secure it against being switched on again.
2. Open the check valves in the flow and return ball valve [a|b] by turning them into position 45°, see chapter 4.2.
3. Connect a heat-resistant hose to the fill and drain valve [g] of the transfer station.

Make sure that the solar fluid is collected in a heat-resistant container.

WARNING



Danger of scalding due to hot solar fluid!

The escaping solar fluid can be very hot!

- ▶ Position and secure the heat-resistant collecting container such that persons nearby are not put at risk when the solar system is drained.

4. Open the fill and drain valve [g] of the transfer station.
5. To accelerate draining of the solar circuit, you can open the air-bleed valve, if present, at the highest point of the solar system.
6. Dispose of the solar fluid observing the local regulations.

5.4 Deinstallation

1. Drain the solar installation as described in the previous section.
2. Disconnect the pipe connections to the solar installation.
3. Disconnect the cable connections between the controller and the sensors (collector / storage tank).
4. Loosen the fastening screws of the station and take the station off the wall.

6 Scope of delivery [specialist]

NOTICE

Serial number

Complaints and requests/orders of spare parts will only be processed with information on the serial number! The serial number is placed on the safety group.

- ▶ In case of a complaint, please send us the entirely completed commissioning report.

6.1 Spare parts controller and insulation SolexMidi TW (6095436)

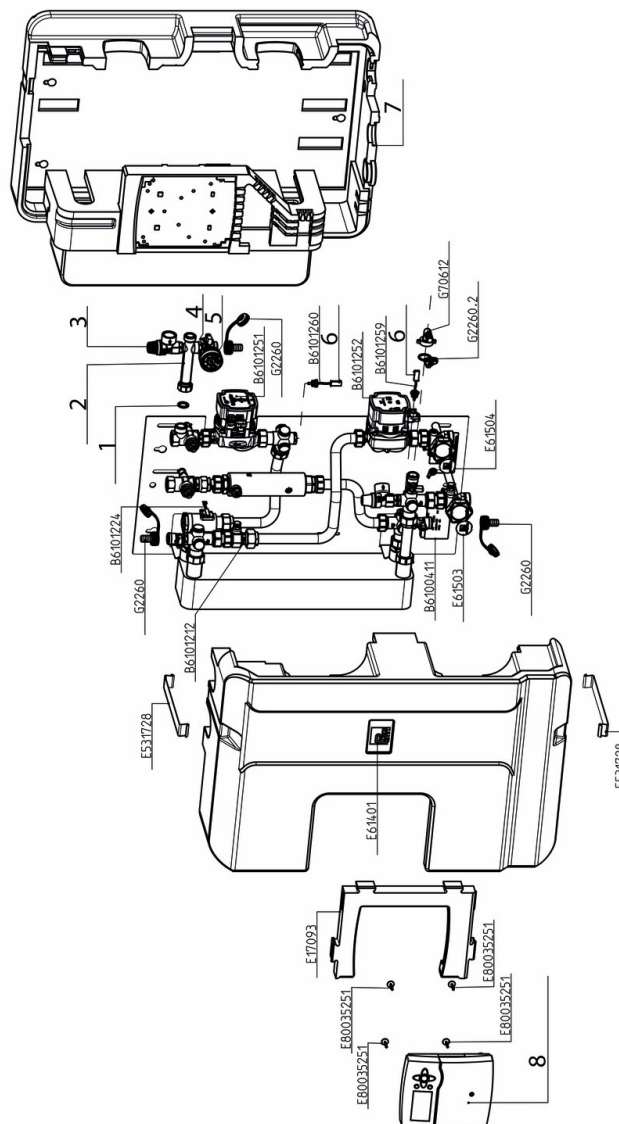

Position	Spare part	Item number
1	Sealing kit, 24.0 x 17.0 x 2.0, ¼", for thread connection ¾", 10 pieces	N00030
2	Safety bar DN 20, fill and drain valve ½"	N00462
3	Pressure relief valve ½" x ¾", 6 bars	N00300
4	Fill and drain valve ½", ¾" ext. thread, ½" int. thread, self-sealing x ½" ext. thread, self-sealing	N00460
5	Pressure gauge 0-6 bars, G ¼" axial; d = 50 mm, 130 °C	N00337
6	Temperature sensor Pt1000, screw-in sensor 9 mm, G¼"	N00230
7	Insulation DN 20	N00249
8	Controller SC5.14 with wiring harness, SuperSeal	E130148103

6 Scope of delivery [specialist]

6.2 Spare parts hydraulics SolexMidi TW (6095436)

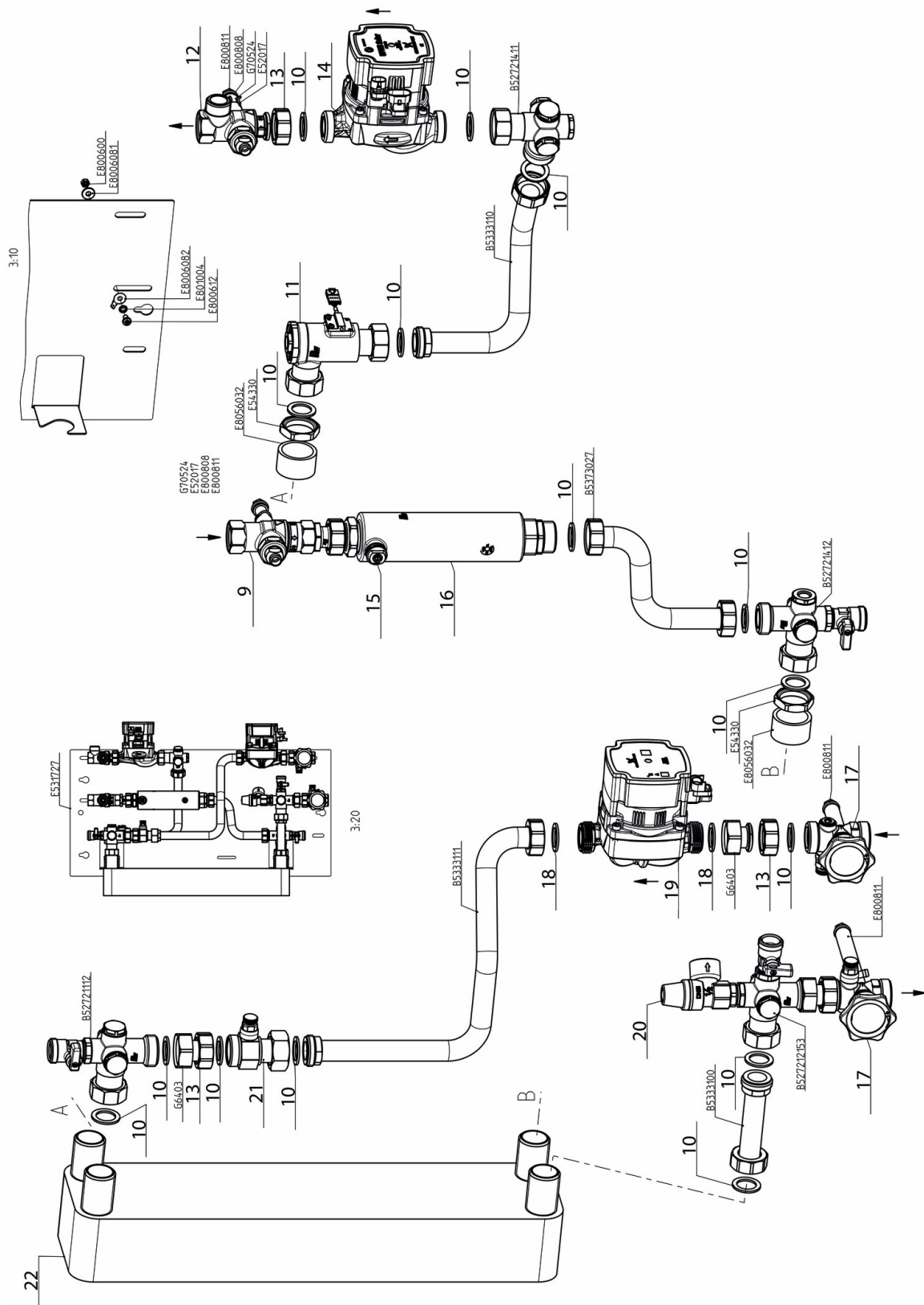

Position	Spare part	Item number
9	Flow ball valve DN 20, ¾" int. thread x ¾" int. thread, with solar check valve	N00291
10	Sealing kit, 30.0 x 21.0 x 2.0, ½", for thread connection 1", 10 pieces	N00024
11	FlowRotor DN 20, 2 - 50 l/min, with gasket and connection cable	N00287
12	Return ball valve DN 20, ¾" int. thread x F ¾" x ¾" ext thread on the right	N00290
13	Union nut G1", passage 28.1 mm, wrench size 37	N00302
14	Grundfos UMP3 Solar 15-145	N00215
	Grundfos Solar PM2 15-145	N00338
15	Vent plug, ⅜" ext thread, self-sealing, EPDM o-ring	N00520
16	Airstop DN 25, 1" ext. thread self-sealing x 1" int. thread flat-sealing, with double nipple 1" ext. thread flat-sealing	565571
17	Piston valve DN 20, 2x 1" ext thread, with drainage	N00211
18	Sealing kit EPDM, 30.0 x 21.0 x 2.0, ½", for thread connection 1", 10 pieces	N00129
19	Grundfos UMP4 15-70 CIL3	N00383
	Grundfos UMP2 15-75 CIL2	N00275
20	Pressure relief valve ½" x ¾", 10 bars	N00008
21	Non return valve DN 20, 1" ext. thread x 1" union nut	N00283
22	Heat exchanger copper solder, with gaskets	N00041

6 Scope of delivery [specialist]

6.3 Spare parts controller and insulation SolexMaxi TW (6096465)

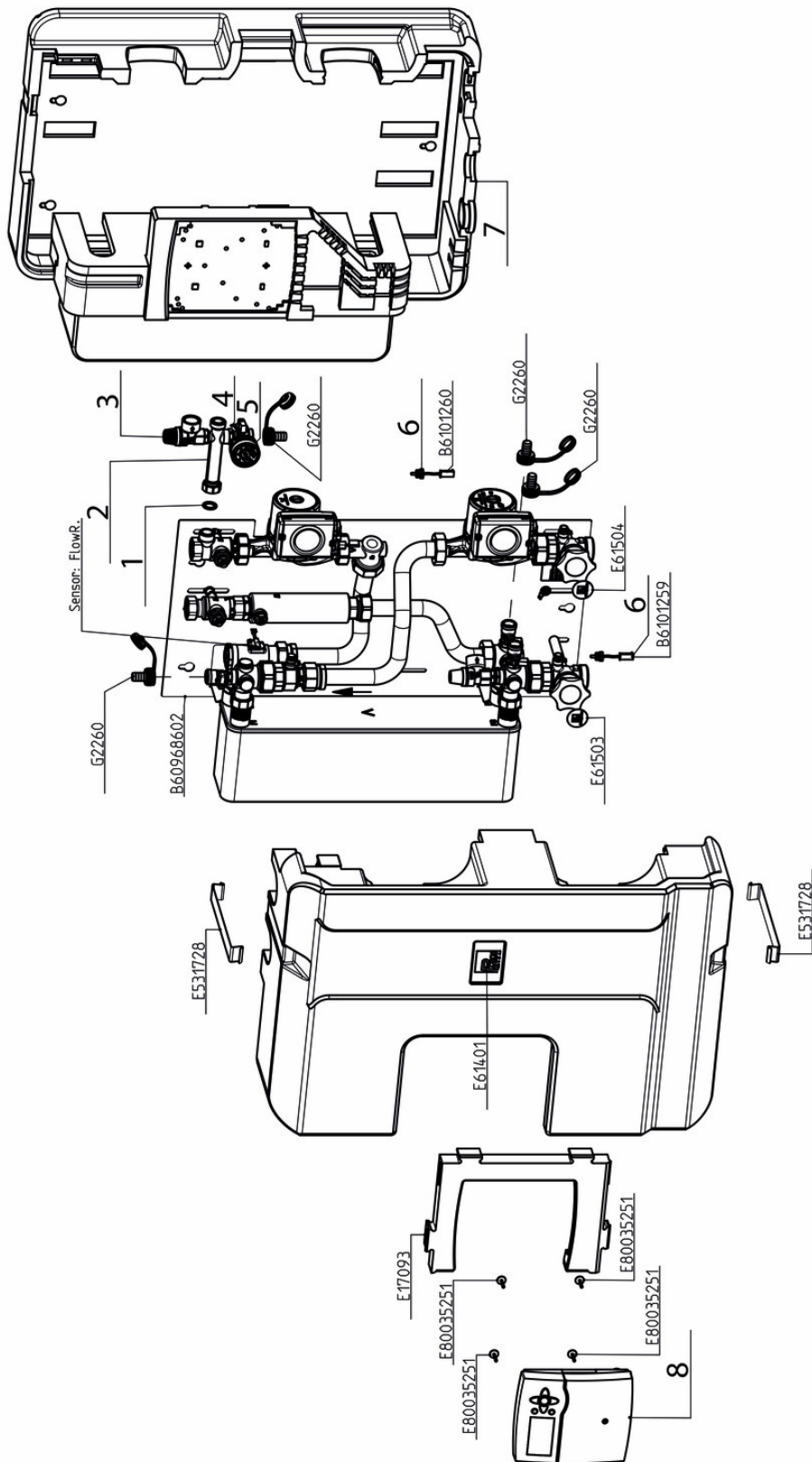

Position	Spare part	Item number
1	Sealing kit, 24.0 x 17.0 x 2.0, ¼", for thread connection ¾", 10 pieces	N00030
2	Safety bar DN 20, fill and drain valve ½"	N00462
3	Pressure relief valve ½" x ¾", 6 bars	N00300
4	Fill and drain valve ½", ¾" ext. thread, ½" int. thread, self-sealing x ½" ext. thread, self-sealing	N00460
5	Pressure gauge 0-6 bars, G ¼" axial; d = 50 mm, 130 °C	N00337
6	Temperature sensor Pt1000, screw-in sensor 9 mm, G¼"	N00230
7	Insulation DN 20	N00249
8	Controller SC5.14 with wiring harness, SuperSeal	E130148101

6 Scope of delivery [specialist]

6.4 Spare parts hydraulics SolexMaxi TW (6096465)

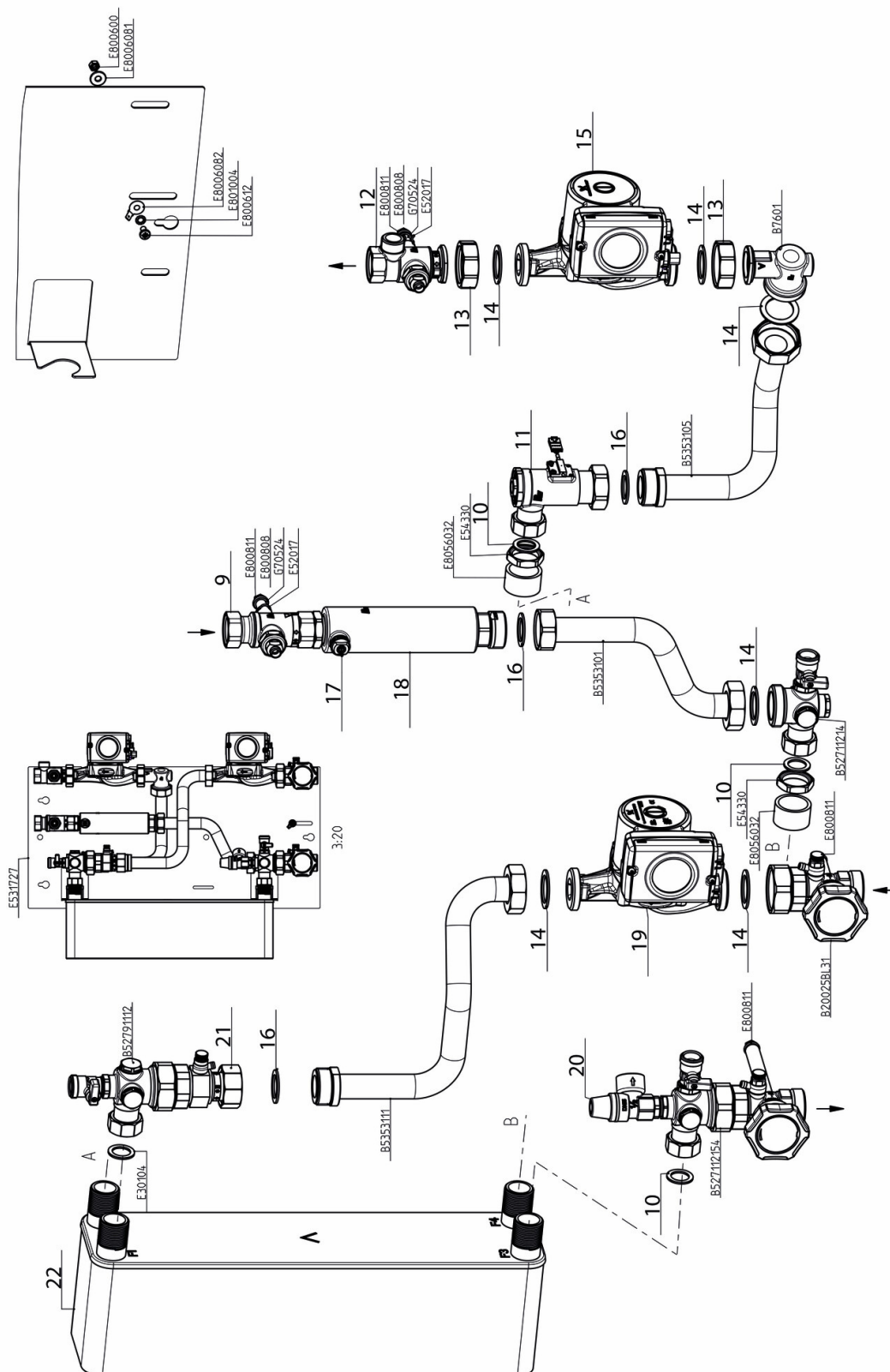

Position	Spare part	Item number
9	Flow ball valve DN 25, 1" int. thread x 1" int. thread, with solar check valve	N00305
10	Sealing kit, 30.0 x 21.0 x 2.0, ½", for thread connection 1", 10 pieces	N00024
11	FlowRotor DN 25, 2 - 50 l/min, with gasket and connection cable	N00200
12	Return ball valve DN 25, F 1" x 1" int. thread, with solar check valve	N00306
13	Union nut G 1½", wrench size 52	N00269
14	Sealing kit, 44.0 x 32.0 x 2.0, 1", for thread connection 1½", 10 pieces	N00036
15	Grundfos Solar PML 25-145	N00226
16	Sealing kit, 38.0 x 27.0 x 2.0, ¾", for thread connection 1¼", 10 pieces	N00174
17	Vent plug, ⅜" ext thread, self-sealing, EPDM o-ring	N00520
18	Airstop DN 25, 1" ext. thread self-sealing x 1" int. thread flat-sealing, with double nipple 1" ext. thread flat-sealing	565571
19	Grundfos UMPL 25-105 N	N00357
20	Pressure relief valve ½" x ¾", 10 bars	N00008
21	Non return valve DN 25, 1¼" ext. thread x 1¼" union nut	N00167
22	Heat exchanger copper solder, with gaskets	N00280

7 Technical data

Dimensions	SolexMidi TW	SolexMaxi TW
Total height	795 mm	829 mm
Total width	662 mm	662 mm
Total depth	298 mm	298 mm
Centre distance, flow / return	120 mm	120 mm
Pipe connections primary	¾" int. thread	1" int. thread
Pipe connections secondary	1" ext. thread	1¼" ext. thread
Connection for expansion vessel	¾" external thread, flat sealing	
Outlet of pressure relief valve	¾" internal thread	
Operating data		
Max. admissible pressure	prim.: 6 bars / sec.: 10 bars	
Max. operating temperature	prim.: 120 °C / sec.: 95 °C	
Max. short-time temperature	140 °C	
Max. propylene glycol content	50 %	
Operating temperature sensors	-25 °C to +120 °C	
Equipment		
Safety valve	prim.: 6 bars / sec.: 10 bars	
Pressure gauge	0-6 bars	
Flow rate measurement device	prim.: FlowRotor: 2-50 l/min	
Sensors	2 x Pt1000 (integrated), 2 x Pt1000 (enclosed)	
Check valves	prim.: 2 x 200 mm wc, can be opened	
(integrated in the ball valves)	sec.: 1 x 150 mm wc, can be opened	
Materials		
Valves and fittings	Brass	
Gaskets	EPDM	

Dimensions	SolexMidi TW	SolexMaxi TW
Check valves	Brass	
Insulation	EPP, $\lambda = 0.041 \text{ W/(m K)}$	

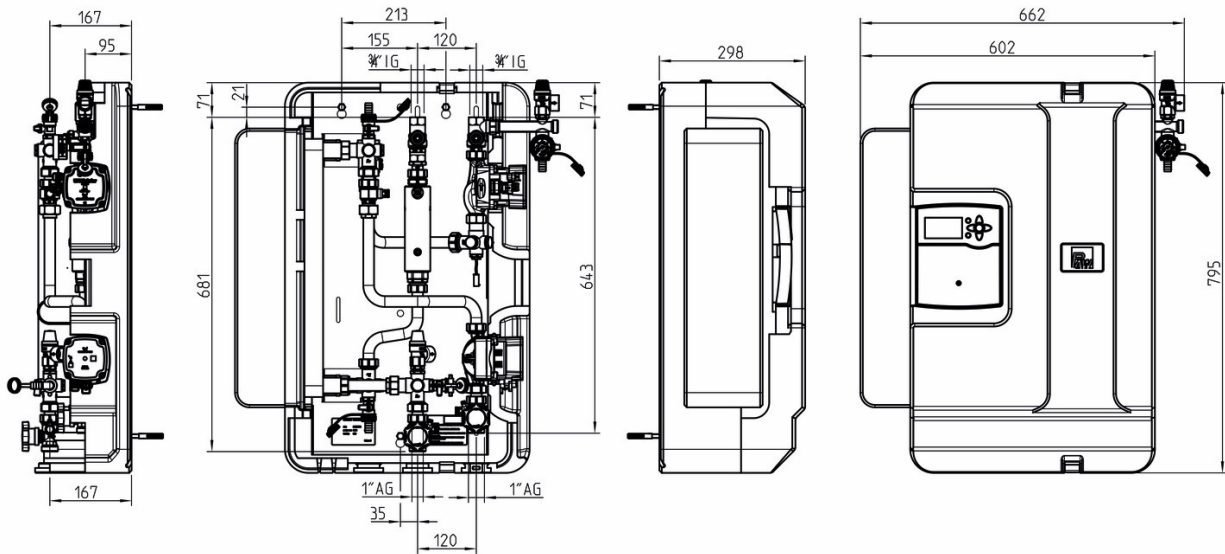
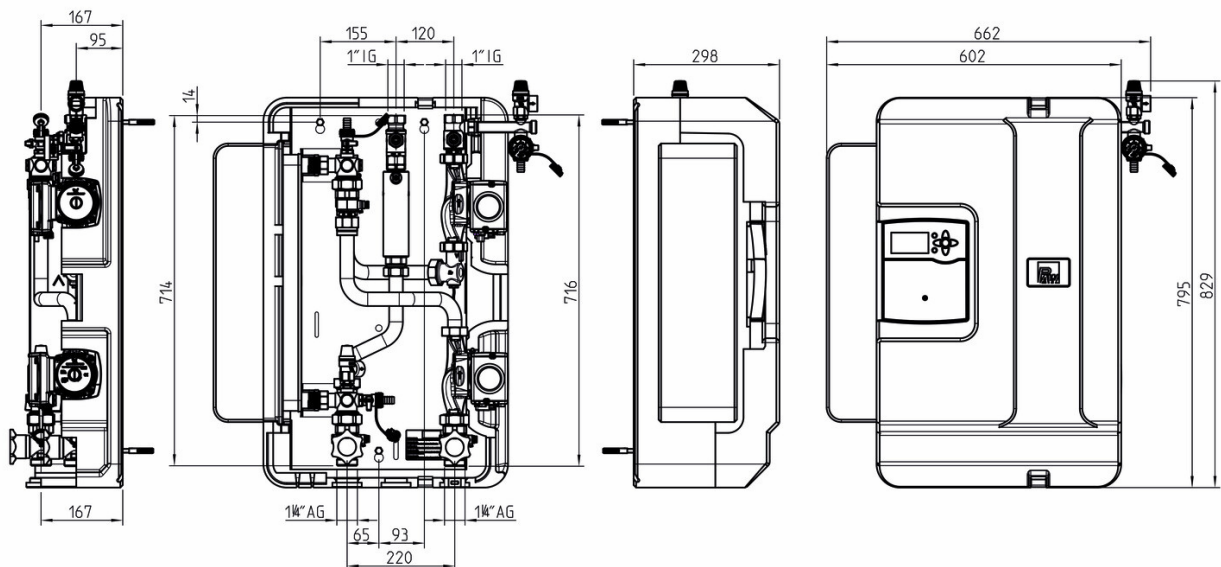
7.1 Dimensional drawing SolexMidi TW

7.2 Dimensional drawing SolexMaxi TW

7 Technical data

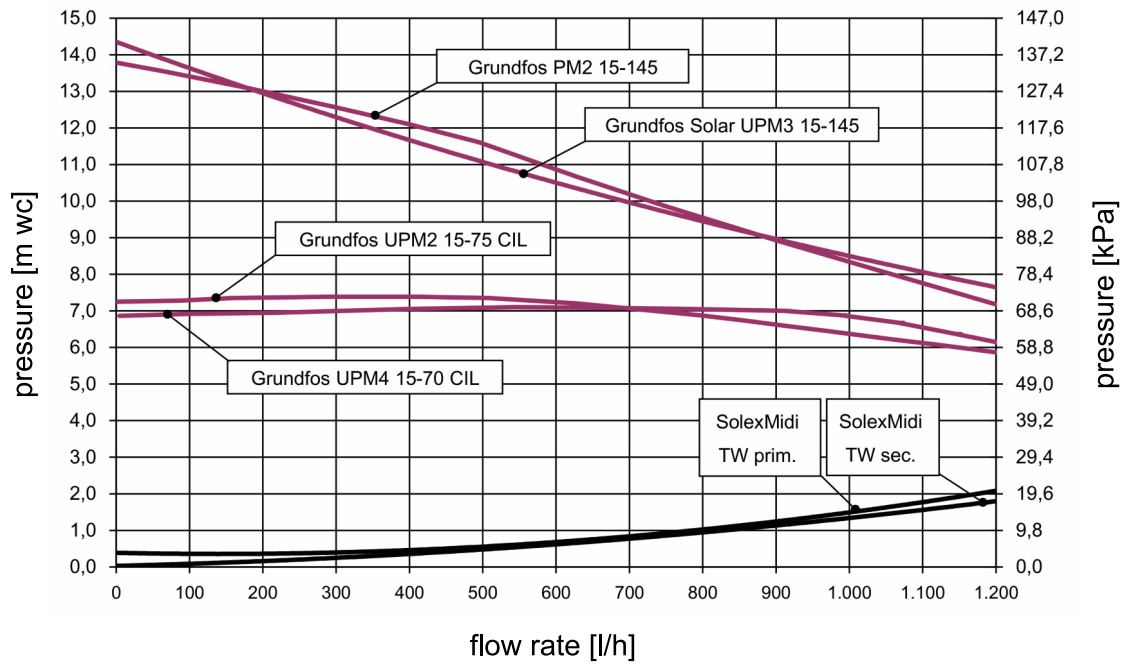
7.3 Pressure drop and pump characteristic curves SolexMidi TW

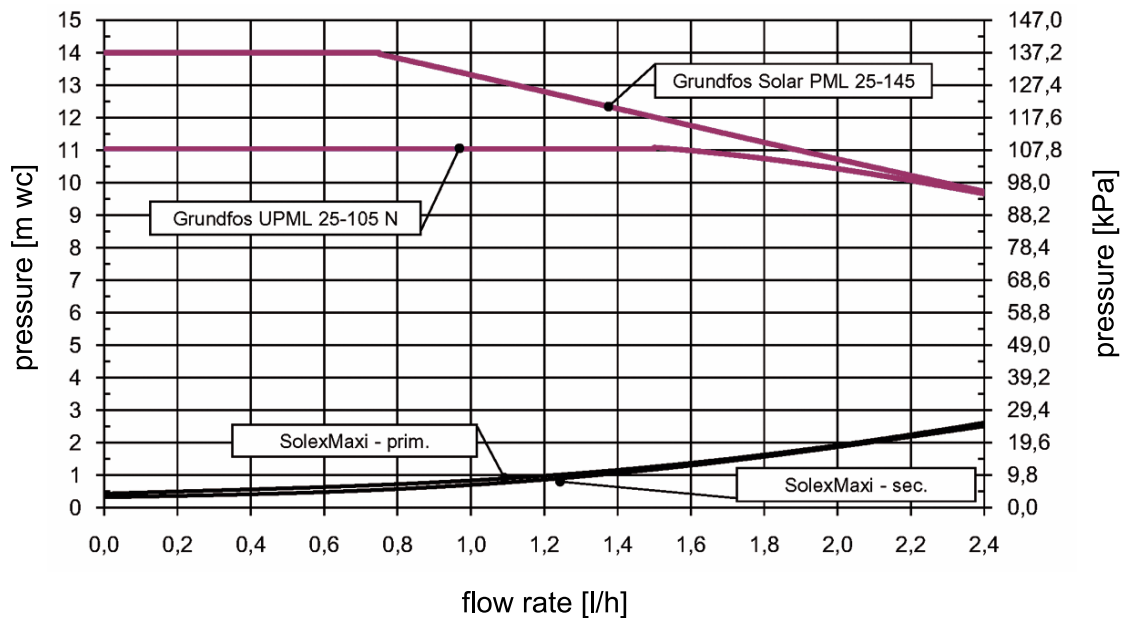

7.4 Pressure drop and pump characteristic curves SolexMaxi TW



8 Function of the check valves [Expert]

The check valves in this station prevent unwanted gravity circulation within their range of use. The functioning of the check valves depends:

- on the system height
- on the temperature difference between storage tank and collector
- on the solar fluid used

The diagram below indicates if the check valves integrated in the station are sufficient for your installation. If the check valves are not sufficient, additional components must be installed to prevent gravity circulation. You can install, for example, syphons ("heat traps"), 2-way valves (zone valves) or additional check valves.

Example:

- The station contains two check valves (2 x 200 mm wc = **400 mm wc**).
- You use a mixture of water and 40% strength propylene glycol as **solar fluid**.
- The installation height between collector and storage tank is **10 m**.

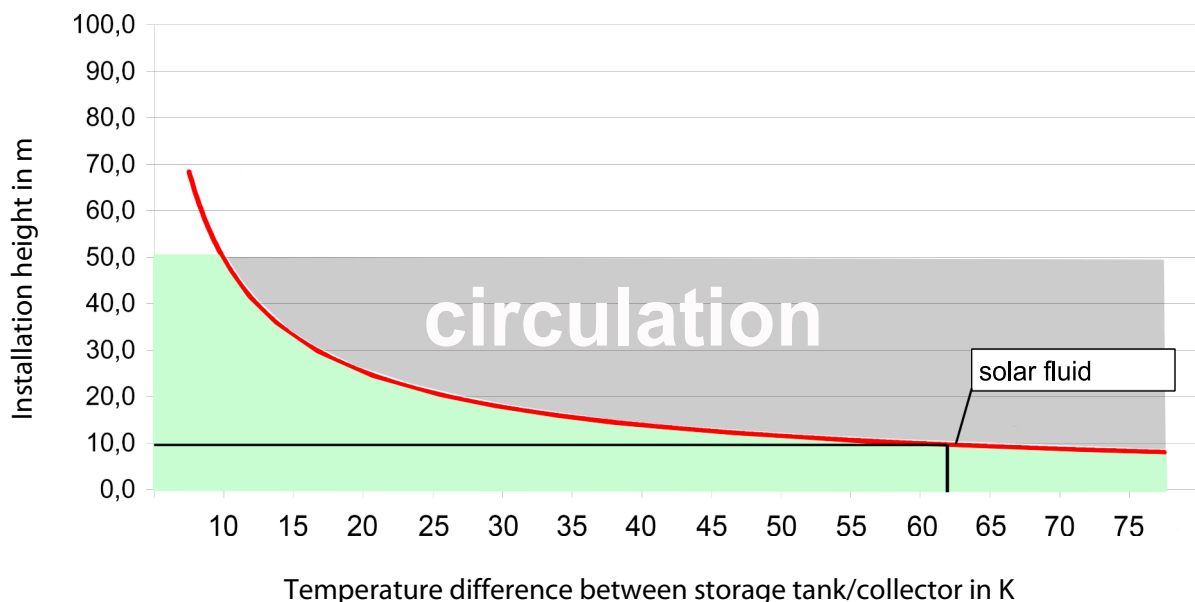

Result:

The check valves prevent gravity circulation up to a temperature difference of **about 62 K**. If the temperature difference between the collector and the tank is larger, the difference in density of the solar fluid will be so large that the check valves are pushed open.

Do you need to know it exactly?

The density of the solar fluid strongly decreases with increasing temperature. In systems of high system heights and with large temperature differences, the difference in density causes gravity circulation. This circulation can result in the storage tank cooling down.

Calculation example: $\Delta p = \Delta \rho * g * h$

Collector temperature: 5 °C: Solar fluid density $\rho_1 = 1042 \text{ kg/m}^3$

Storage tank temperature: 67 °C: Solar fluid density $\rho_2 = 1002.5 \text{ kg/m}^3$

$$\Delta \rho = \rho_1 - \rho_2 = 39.5 \text{ kg/m}^3$$

$$g = 9.81 \text{ m/s}^2$$

Installation height $h = 10 \text{ m}$

$$\Delta p = 3875 \text{ Pa} = 395 \text{ mm wc}$$

The two check valves of the station (2 x 200 mm wc) are sufficient for an installation height of 10 m and a temperature difference of up to 62 K between the collector and the tank.

9 Disposal

NOTICE

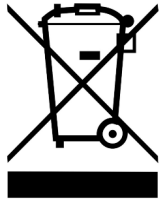

Electrical and electronic devices must not be disposed of in the household waste.

For your return, there are free collection points for electrical appliances and, if necessary, additional points of acceptance for the reuse of the devices in your area.

The addresses can be obtained from your city or communal administration.

If the old electrical or electronic device contains personal data, you are responsible for deleting it before returning the device.

Batteries and rechargeable batteries must be removed prior to the disposal of the product. Depending on the product equipment (partly with optional accessories), single components can also contain batteries and rechargeable batteries.

Please observe the disposal symbols on the components.

Disposal of transport and packaging materials

The packaging materials are made of recyclable materials and can be disposed of with recyclable materials.

10 Commissioning report

System operator			
Location of installation			
Collectors (number / type)			
Collector surface	m ²		
System height	m (height difference between the station and the collector field)		
Pipeline	diameter =	mm;	length = m
Venting (collector field)	<input type="checkbox"/> not available	<input type="checkbox"/> vented	
	<input type="checkbox"/> manual vent valve	<input type="checkbox"/> automatic vent valve	
Airstop (station)	<input type="checkbox"/> vented		
Solar fluid (type)	% glycol		
Antifreeze (checked):	°C	serial numbers	
Flow rate	l/m	<ul style="list-style-type: none"> ● station 	
Pump (type)			<ul style="list-style-type: none"> ● flow rate sensor
Pump speed level		<ul style="list-style-type: none"> ● temperature sensors 	
System pressure	mbars		<ul style="list-style-type: none"> ● controller
Expansion tank (type)		<ul style="list-style-type: none"> ● software version 	
Initial pressure	mbars		
Safety valve	<input type="checkbox"/> checked		
Check valves	<input type="checkbox"/> checked		
Installation company	Date, signature		

Item no. 99609x4x5-mub-en

Translation of the original instructions

We reserve the right to make technical changes without notice!

Printed in Germany – Copyright by PAW GmbH & Co. KG

PAW GmbH & Co. KG

Böcklerstraße 11

31789 Hameln, Germany

www.paw.eu

Phone: +49-5151-9856-0

Fax: +49-5151-9856-98