



Installation and Operation Instructions

Domestic hot water modules

FriwaMidi - DN 20

FriwaMaxi - DN 25

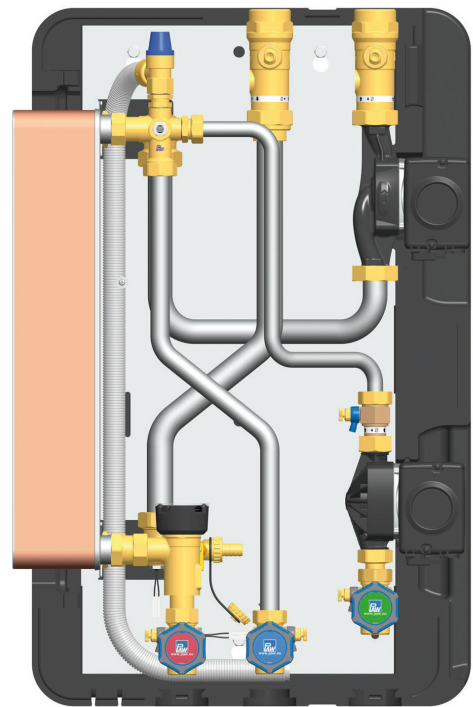

Table of Contents

1	General Information.....	4
1.1	Scope of these instructions.....	4
1.2	About this product.....	6
1.3	Designated use.....	7
2	Safety instructions.....	8
3	Product description.....	10
4	Dimensioning and planning.....	11
4.1	Dimensioning of the tank.....	13
4.2	Water quality requirements.....	14
5	Circulation mode.....	16
6	Mounting and installation [specialist].....	17
7	Commissioning [specialist].....	20
7.1	Filling the primary circuit.....	21
7.2	Commissioning of the controller.....	22
7.3	Adjustment of the temperature.....	24
7.4	Maximum withdrawal flow rate FriwaMidi.....	25
7.5	Maximum withdrawal flow rate FriwaMaxi.....	28
8	Maintenance.....	31
8.1	Inspection.....	31
8.2	Maintenance.....	32
9	Scope of delivery [specialist].....	33
9.1	Spare parts control and insulation FriwaMidi.....	33
9.2	Spare parts hydraulics FriwaMidi.....	34
9.3	Spare parts control and insulation FriwaMaxi.....	35
9.4	Spare parts hydraulics FriwaMaxi.....	36
10	Technical data.....	39
10.1	Dimensional drawings.....	41
10.2	Pressure drop and pump characteristic curves FriwaMidi.....	42
10.3	Pressure drop and pump characteristic curves FriwaMaxi.....	42



Table of Contents

11	Disposal.....	43
12	Commissioning report.....	44
13	Notes.....	45

1 General Information



Carefully read these instructions before installation and commissioning.

Save these instructions in the vicinity of the installation for future reference.

1.1 Scope of these instructions

These instructions describe the installation, commissioning, function and operation of the domestic hot water modules FriwaMidi and FriwaMaxi. The chapters called [specialist] are intended for specialists only.

For other components of the system, such as tanks, controllers and pumps, please observe the instructions of the corresponding manufacturer.

Station	Item number	Controller FC3.10	Primary pump	Circulation	Heat exchanger
FriwaMidi	6405511		Grundfos UPM2 25-75	Optional:	copper solder, 40 plates
	6405531			6404123	coated, 40 plates
FriwaMidi with circulation	6405516		Grundfos UPM2 25-75	Grundfos UPM2 15-75 CIL2	copper solder, 40 plates
	6405536				coated, 40 plates

1 General Information

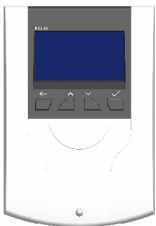
Station	Item number	Controller FC3.10	Primary pump	Circulation	Heat exchanger
FriwaMaxi	6406511		Grundfos UPML 25-105	Optional: 6404123	copper solder, 60 plates
	6406531				coated, 60 plates
FriwaMaxi with circulation	6406516		Grundfos UPML 25-105	Grundfos UPM2 15-75 CIL2	copper solder, 60 plates
	6406536				coated, 60 plates

These articles are covered by Article 4(3) of the Pressure Equipment Directive 2014/68/EU and are designed and manufactured in accordance with good engineering practice.

The domestic hot water module complies with the relevant directives and is therefore labelled with the CE mark. The Declaration of Conformity is available upon request, please contact the manufacturer.

1.2 About this product

The FriwaMidi and FriwaMaxi are domestic hot water modules which heat potable water operating on the principle of a flow-type water heater.

The domestic hot water module is a premounted group of fittings checked for tightness and used to transfer the heat between the buffer tank and the domestic hot water circuit.

It contains a preset controller and important valves and fittings and safety equipment to operate the unit:

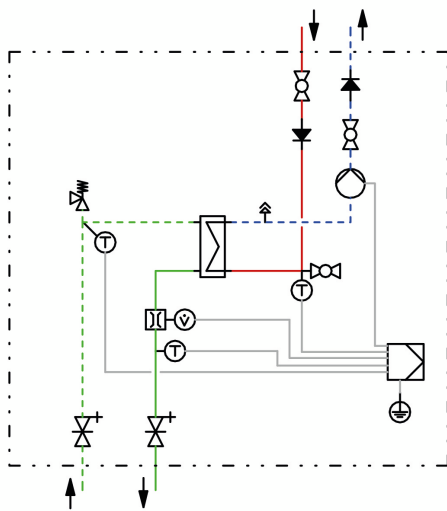

Domestic hot water module without circulation

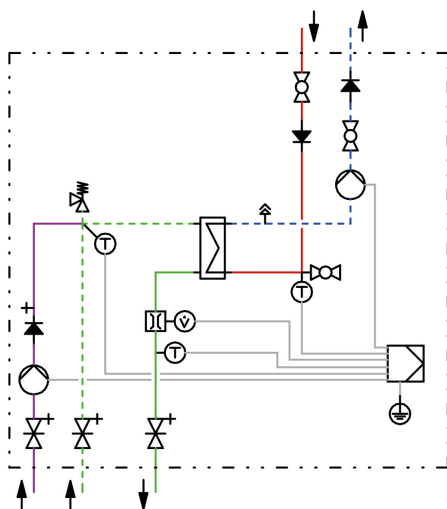

Domestic hot water module with circulation

- Ball valves in the primary circuit
- Piston valves in the secondary circuit
- Safety valve in the secondary circuit
- Premounted controller
- Temperature sensor at the cold water inlet
- Temperature sensors in the heating circuit flow line
- Temperature sensor at the domestic hot water outlet
- Flow meter at the domestic hot water outlet
- Fill and drain valve to drain the heat exchanger
- Manual vent valve for venting the heat exchanger and the pump



1 General Information

1.3 Designated use

The domestic hot water module must only be mounted in heating installations between the buffer tank and the domestic hot water circuit. Due to its design, the station must be mounted and operated in a vertical position! The technical limit values specified in these instructions must be observed.

Only use PAW accessories with the domestic hot water module. Improper usage excludes any liability claims.



Do not put the module into operation in case of any visible damage.

2 Safety instructions

The installation and commissioning as well as the connection of electrical components require technical knowledge commensurate with a recognised vocational qualification as a fitter for plumbing, heating and air conditioning technology, or a profession requiring a comparable level of knowledge [specialist].

The following must be observed during installation and commissioning:

- relevant local and national regulations
- accident prevention regulations of the professional association
- instructions and safety instructions mentioned in these instructions

 CAUTION	
	<p>Risk of burns!</p> <p>Valves, fittings and pump may heat up to more than 95 °C during operation.</p> <ul style="list-style-type: none"> ▶ The insulating shell must remain closed during operation.

WARNING	
<p>Malfunction!</p> <ul style="list-style-type: none"> ▶ The DHW module must be integrated in the potential equalisation of the electric installation. This can be guaranteed by establishing a potential equalisation connection to the main potential connection according to regulations or by the connected pipe system. 	

NOTICE

Material damage due to mineral oils!

Mineral oil products cause lasting damage to seals made of EPDM, whereby the sealant properties are lost. We do not assume liability nor provide warranty for damage to property resulting from sealants damaged in this way.

- ▶ It is imperative to prevent the EPDM sealing elements from making contact with substances containing mineral oils.
- ▶ Use a silicone- or polyalkylene-based lubricant free of mineral oil such as Unisilikon L250L and Syntheso Glep 1 from Klüber or a silicone spray.

3 Product description

Connections

- 1 Primary side: Return to the buffer tank
- 2 Secondary side: hot water circulation, return
- 3 Secondary side: Cold water inlet
- 4 Hot water outlet
- 5 Primary side: Flow from the buffer tank

Equipment

- A Ball valve with check valve
- B Primary pump
- C Non-return valve with drain valve
- D Circulation pump
- E Piston valve with drain valve
- F Piston valve with drain valve
- G Piston valve with drain valve and temperature sensor
- H Fill and drain valve and temperature sensor
- I Flow meter FlowSonic
- J Plate heat exchanger
- K Circulation line
- L Vent valve (primary circuit)
- M Temperature sensor and pressure relief valve 10 bar, suitable for DHW
- N Ball valve with check valve

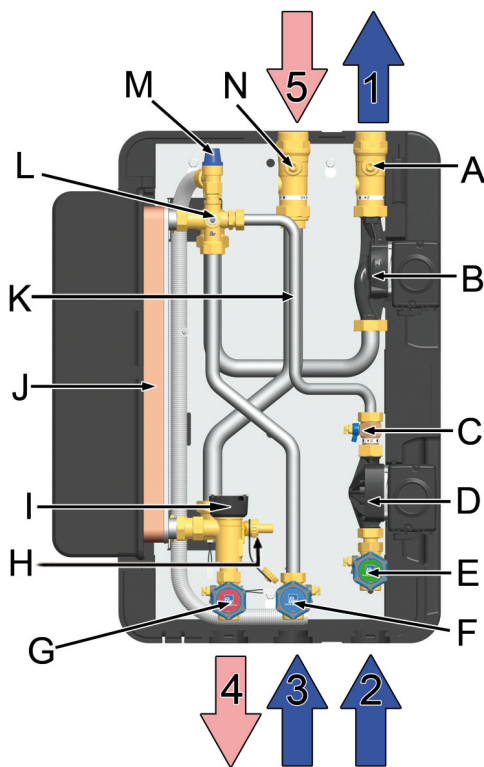

Example: FriwaMaxi with circulation

Only for the protection of the station. Does not replace the pressure relief valve that has to be mounted on site!

4 Dimensioning and planning

The DHW module will only work flawlessly if the installation meets certain requirements. Please take some time to plan the assembly.

WARNING	
	<p>Danger of scalding due to hot water!</p> <p>Undesirable circulation of water in the primary circuit can cause the exit of water of up to 90 °C at the withdrawal point.</p> <ul style="list-style-type: none"> ▶ External pumps must not be installed between the domestic hot water module and the buffer tank. ▶ The domestic hot water module must not be connected to a distribution manifold of a heating circuit.

Mounting example:

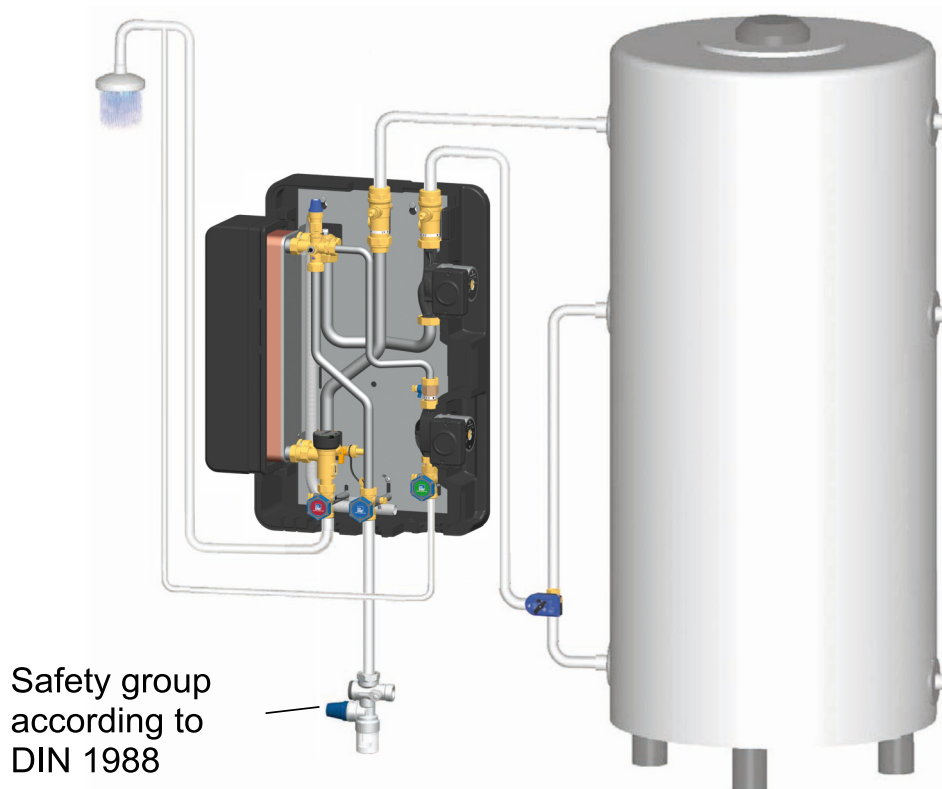

FriwaMidi with optional circulation set (item no. 6404123) and with optional return distribution
(FriwaMidi: Item no. 640423, FriwaMaxi: Item no. 640424)

NOTICE

Use of trace heating tapes

Installations without a circulation line with an increased pipe content can cause a considerable drop of temperature in the pipes during longer withdrawal breaks. This leads to a delayed start behaviour of the domestic hot water module, which slows down the regulation of the set nominal temperature.

This effect can be reinforced when using electrical trace heating systems in combination with short withdrawals. There is a risk that different temperature ranges will develop in the domestic hot water line due to the delayed start behaviour. This can lead to initially fluctuating outlet temperatures during subsequent longer withdrawals.

Therefore, we do not recommend an electric trace heating system. If an installation is unavoidable, the following steps are recommended:

- ▶ If there is a long pipe section between the buffer storage tank and the domestic hot water module, the comfort function should be activated (increased tendency to calcification). We recommend the shortest possible installation routes between the buffer tank and the DHW module.
- ▶ Avoid short withdrawals.
- ▶ Instead of an over-dimensioned domestic hot water module, we recommend cascading several smaller modules.

Optimal operation of the station

In order to guarantee an optimal control, no additional hydraulic pressure losses should occur on the primary side (f. ex. due to the installation of a mud strainer, a strainer or a mixing valve).

4 Dimensioning and planning

4.1 Dimensioning of the tank

The following table helps you to calculate the approximately required volume of the buffer tank.

Temperature in the buffer tank	Domestic hot water temperature set at the controller	Required tank volume per litre of hot water
50 °C	45 °C	1.3 litres
60 °C*	45 °C	0.8 litre
	50 °C	1.0 litre
	55 °C	1.4 litres
70 °C	45 °C	0.7 litre
	50 °C	0.8 litre
	55 °C	0.9 litre
80 °C	45 °C	0.5 litre
	50 °C	0.6 litre
	55 °C	0.7 litre

*Calculation example for the dimensioning of the buffer tank:

Temperature in the buffer tank: 60 °C

Required withdrawal flow rate at the tap: 20 l/min

Domestic hot water temperature set at the controller: about 45 °C

How large must be the tank to allow a continuous withdrawal during 20 minutes without post-heating?

$$20 \text{ l/min} \times 20 \text{ min} = 400 \text{ l}$$

$$400 \text{ l} \times 0.8 = 320 \text{ l}$$

The heated part of the buffer tank must have a volume of 320 litres.

4.2 Water quality requirements

The domestic hot water modules constructively decrease the precipitation of chalk in the heat exchanger. For installations with an elevated total hardness of the potable water and/or high temperatures, a water treatment is recommended. Depending on the chemical composition of the water at the installation site, the selection and adequacy of the plate heat exchanger has to be checked. Please observe the following table: **Influence of the water quality on the corrosion resistance for domestic hot water applications**

Water content	Concentration (mg/l or ppm)	Time limits	Heat exchanger with copper solder	Heat exchanger with Sealix® sealing
Alkalinity (HCO ₃ ⁻)	< 70	within 24 hours	0	+
	70-300		+	+
	> 300		0/+	+
Sulphate (SO ₄ ²⁻)	< 70	no limit	+	+
	70-300		0/-	+
	> 300		-	+
HCO ₃ ⁻ / SO ₄ ²⁻	> 1.0	no limit	+	+
	< 1.0		0/-	+
Electrical conductivity	< 10 µS/cm	no limit	0	+
	10-500 µS/cm		+	+
	> 500 µS/cm		0	+
pH value	< 6.0	within 24 hours	0	+
	6.0-7.5		0	+
	7.5-9.0		+	+
	9.0-10		0	0
	> 10.0		0	-
Ammonium (NH ₄ ⁺)	< 2	within 24 hours	+	+
	2-20		0	+
	> 20		-	-

4 Dimensioning and planning

Water content	Concentration (mg/l or ppm)	Time limits	Heat exchanger with copper solder	Heat exchanger with Sealix® sealing
Chloride (Cl ⁻)	< 100	no limit	+	+
	100-200		+	+
	200-300		+	+
	> 300		0/+	0
Free chlorine (Cl ₂)	< 1	within 5 hours	+	+
	1-5		0	0
	> 5		0/-	0
Hydrogen sulphide (H ₂ S)	< 0.05	no limit	+	+
	> 0.05		0/-	0
Free (aggressive) carbon dioxide (CO ₂)	< 5	no limit	+	+
	5-20		0	+
	> 20		-	+
Total hardness (°dH)	4.0-8.5	no limit	+	+
Nitrate (NO ₃ ⁻)	< 100	no limit	+	+
	> 100		0	+
Iron (Fe)	< 0.2	no limit	+	+
	> 0.2		0	+
Aluminium (Al)	< 0.2	no limit	+	+
	> 0.2		0	+
Manganese (Mn)	< 0.1	no limit	+	+
	> 0.1		0	+

+ Good resistance under normal conditions

0 Corrosion may occur, especially if further factors are evaluated with 0

- Use is not recommended

5 Circulation mode

The domestic hot water module is optionally equipped with a circulation pump. Modules without circulation can be subsequently equipped with a circulation set for an internal retrofitting.

For the operation of the circulation pump, three possible operation modes are stored in the controller (see controller instructions, chapter *Circulation*).

- **Pulse-controlled operation** (depending on the demand / requirements):

The short actuation of a hot water tap (tap pulse: less than 5 sec.) starts the circulation pump. The circulation pump will then run for several minutes (adjustable).

- **Time-dependent operation:**

The operation of the circulation pump can be set on a week clock within freely selectable periods of time. In this operation mode, the circulation is activated at the beginning of the period of the time chosen. The circulation will stop after the end of the chosen period of time.

- **Temperature-dependent operation:**

In this operation mode, the circulation is only activated if the adjustable minimum temperature at the circulation temperature sensor is not reached. The circulation stops after the adjustable switch-off temperature has been reached.

The operating modes can be combined with each other as wished, e.g. the time- and the temperature-dependent operating modes. The circulation is only activated if the temperature at the circulation temperature sensor falls below the required value and if the time window is active.

If the pulse-controlled operation mode is additionally activated, the circulation pump runs continuously during the time slot and can be activated by a tap pulse outside the time slot. The circulation prematurely stops if the adjusted switch-off temperature is exceeded.

NOTICE

Damage to property!

When the DHW module is delivered, the circulation is not activated (see controller instructions, chapter *Circulation*). It is mandatory to select and preset the operation mode. The revolution speed of the circulation pump is defined via the PWM signal (factory setting: 40%).

6 Mounting and installation [specialist]

The domestic hot water module must only be connected with the storage tank by separate connections for the flow and return. External pumps must not be installed between the domestic hot water module and the buffer tank. The circulation of water causes considerable temperature fluctuations.

The DHW connection must be carried out in accordance with the relevant norms (e.g. DIN 1988)!

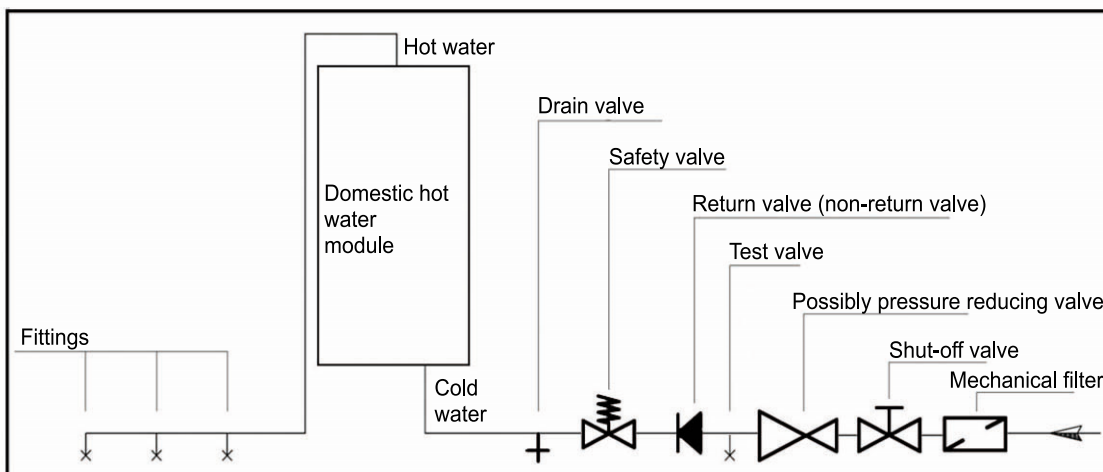

NOTICE

Damage to property!

The pressure relief valve integrated in the station does not replace the safety groups of the potable water connection as per DIN 1988. The pressure relief valve only protects the module from overpressures in case of servicing.

NOTICE

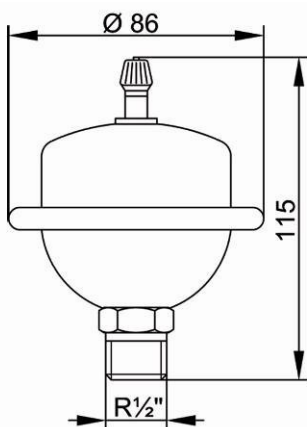

Damage to property!

If there are water supplies that may cause pressure surges (for example flush valves, washing machines or dishwashers) connected to the same mains as the domestic hot water module, we recommend the installation of water hammer arresters close to the place where these pressure surges may be caused.

WARNING

Risk to life and limb due to electric shock!

- ▶ Prior to commencing electrical work on the controller, pull the mains plug!
- ▶ Only after completing all work, plug the mains plug into a socket. This avoids an unintentional start of the motors.

NOTICE
Damage to property!

The installation site must be dry, stable, frost-proof and protected against ultraviolet radiation in order to prevent material damage of the installation.

1. Determine the mounting location of the domestic hot water module near the buffer tank. The pipes in the heating circuit must not exceed a length of 4 m (for DN 32).
2. A drilling template can be used in order to facilitate the installation. You will find the drilling template on the station.
3. Copy the measures for the mounting holes to the wall.
4. Drill the holes and insert adequate wall plugs into the holes.
5. Turn the screws into the wall plugs in such a way that about 40 mm of each screw still stick out.
6. Remove the station from the packaging.
7. Remove the insulating front shell.
8. Hang the domestic hot water module onto the screws. Tighten the screws, so that the sides of the insulation are flush to the wall.
9. Connect the domestic hot water module with the installation by using the piping according to the adjacent figure.

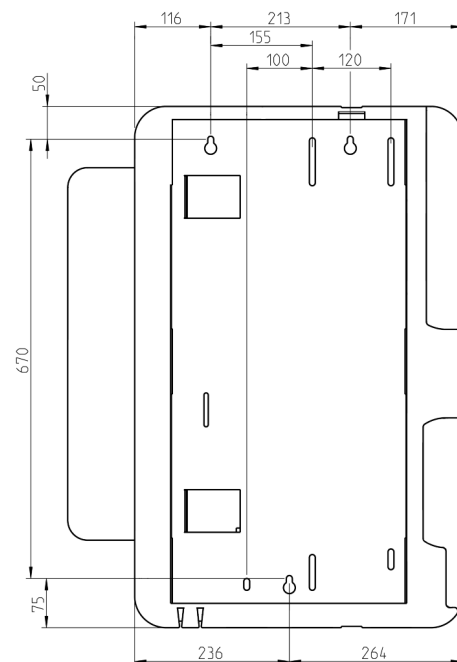

drilling template

6 Mounting and installation [specialist]

1 Primary side:

Return to the buffer tank,

Connection **FriwaMidi**: 1½" ext. thread,

Connection **FriwaMaxi**: 2" ext. thread,

Piping:

FriwaMidi: at least DN 25, 28 x 1.5 mm

FriwaMaxi: at least DN 32, 35 x 1.5 mm,
maximum length 2 m

2 Secondary side:

Hot water circulation, return,

Connection: 1" ext. thread, flat seal.

3 Secondary side:

Cold water inlet,

Connection **FriwaMidi**: 1" ext. thread, flat seal.,

Connection **FriwaMaxi**: 1¼" ext. thread, flat seal.

4 Secondary side:

Hot water outlet,

Connection **FriwaMidi**: 1" ext. thread, flat seal.,

Connection **FriwaMaxi**: 1¼" ext. thread, flat seal.

5 Primary side:

Flow from the buffer tank,

Connection **FriwaMidi**: 1½" ext. thread,

Connection **FriwaMaxi**: 2" ext. thread,

Piping:

FriwaMidi: at least DN 25, 28 x 1.5 mm,

FriwaMaxi: at least DN 32, 35 x 1.5 mm,
maximum length 2 m

Pipe distance to the wall

(primary) = 95 mm

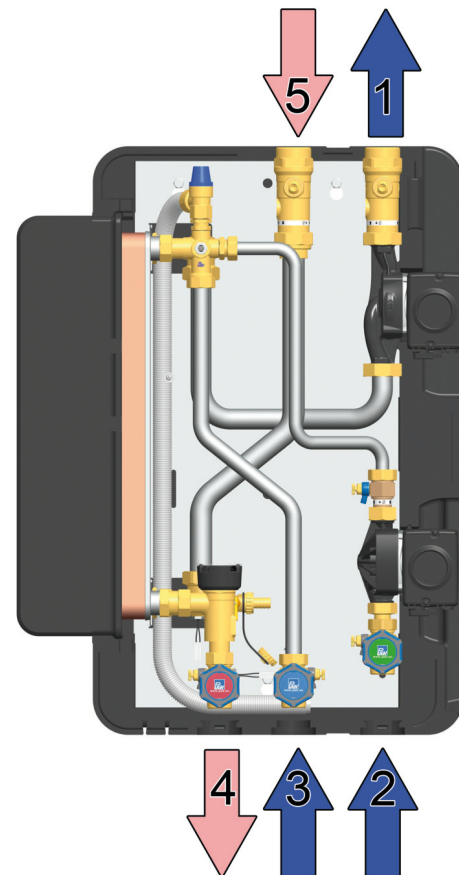

Pipe distance to the wall

(secondary) = 167 mm

7 Commissioning [specialist]

NOTICE

Open the valves in the pipes and in the module **slowly** in order to prevent pressure surges.

Functioning check valve

The ball valves (A) and (N) in the primary circuit are equipped with a check valve, in order to avoid unwanted gravity circulation.

To vent and flush the installation, the check valves must be open. For this purpose, turn the ball valves into **position 45°**. The check valve is not operating.

For the operation of the installation, all valves must be **completely** open (**position 0°**).

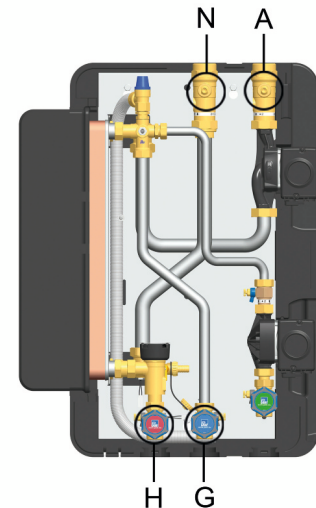

position 0°

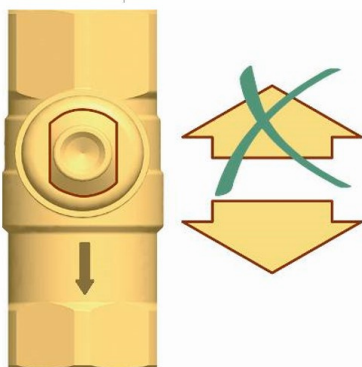

Check valve is operating,
flow only in flow direction.

position 45°

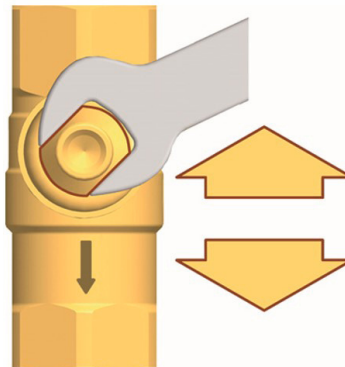

Check valve not operating,
flow in both directions.

position 90°

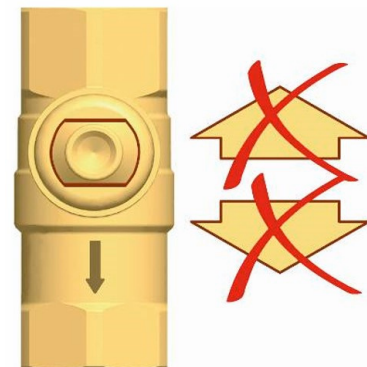

Ball valve closed,
no flow.

7 Commissioning [specialist]

7.1 Filling the primary circuit

WARNING



Danger of scalding due to hot water!

The system is under pressure. By opening the safety / vent valve, hot water with a temperature of up to 90 °C may exit and cause personal injury.

- ▶ Open each valve slowly and with sufficient distance.

If the storage tank is (partly) filled

1. Slowly open the ball valve (N) by turning it into **position 0°**.
2. Fill the storage tank using the fill valves available on site until an operating pressure of about 1.5 bars* is reached. Use heating water compliant with the standards VDI 2035 / ÖNorm H5195-1.
3. Manipulate the vent valve (L) cautiously to let the air escape.
4. Close the vent valve (L).
5. Close the ball valve (N) by turning it into **position 90°**.
6. Check the operating pressure of the storage tank after the venting and increase the pressure if necessary.
7. Open the ball valves (A) and (N) completely by turning them into **position 0°**.

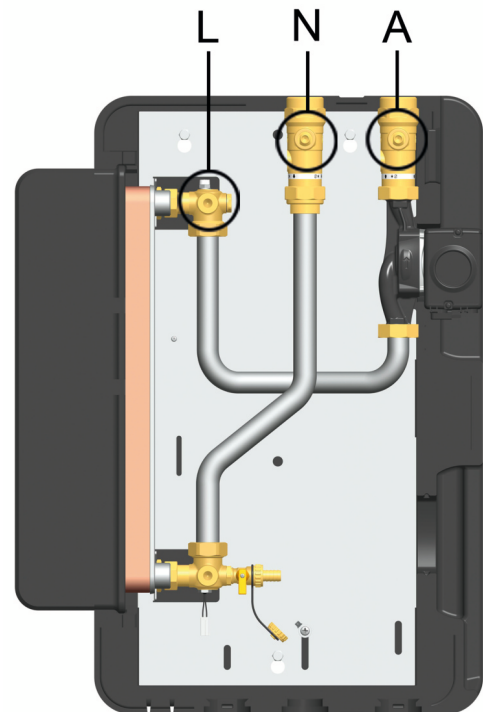

Primary circuit

* 1.5 bars in the primary circuit = recommended minimum value

The pressure also depends on the individual system pressures and on the components of the heating installation!

7.2 Commissioning of the controller

WARNING

Risk to life and limb due to electric shock!

- ▶ Check whether the sensors and pumps have been connected to the controller and the controller housing is closed.
- Only under these circumstances, the mains plug of the controller can be plugged into a socket.

1. Connect the domestic hot water module to the mains (230 V, 50 Hz) by using the premounted connection cable.
2. Carry out the commissioning of the controller (see controller instructions, chapter *Commissioning*). After that, start the pump in the automatic/manual mode (PWM signal = 100 %, see controller instructions chapter *Automatic/manual mode*).
3. Let the pump run for several minutes to vent the domestic hot water module.
4. If the air noises do not stop, carefully manipulate the vent valve (L) while the pump is still running and let the air escape.

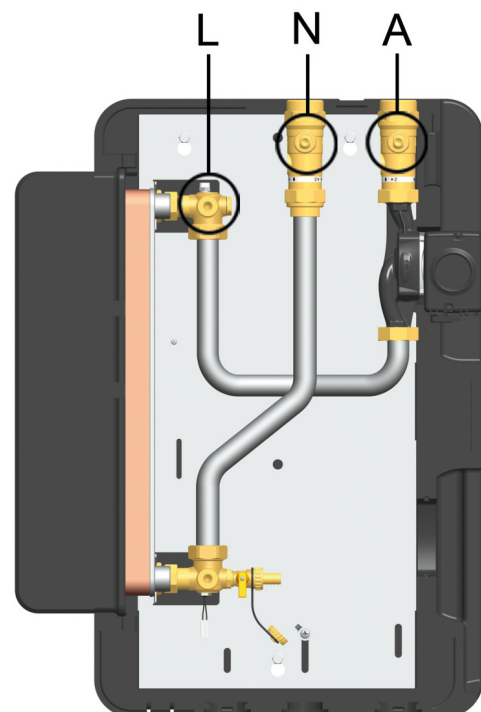
Primary circuit

7 Commissioning [specialist]

5. If the air noises have stopped, the pump can be switched off.
6. To do so, in the automatic/manual mode, set the pump to "Automatic".
7. Slowly open the piston valves (F) and (G) on the secondary side.

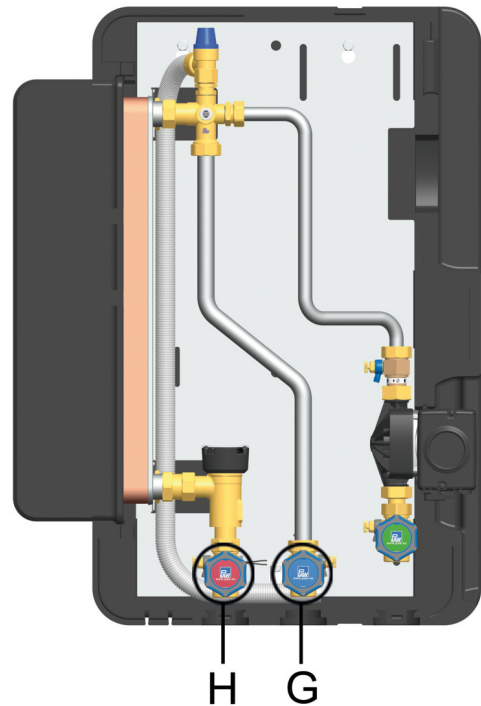

Secondary circuit

8. Open a withdrawal point for domestic hot water (for example a tap) with a flow rate of at least 10 l/min and let the water run for about 2 minutes to vent the secondary circuit. Close all withdrawal points of the secondary circuit afterwards.
9. Make sure that the domestic hot water module is correctly integrated into the potential equalisation of the installation.
10. The domestic hot water module is now ready for operation.

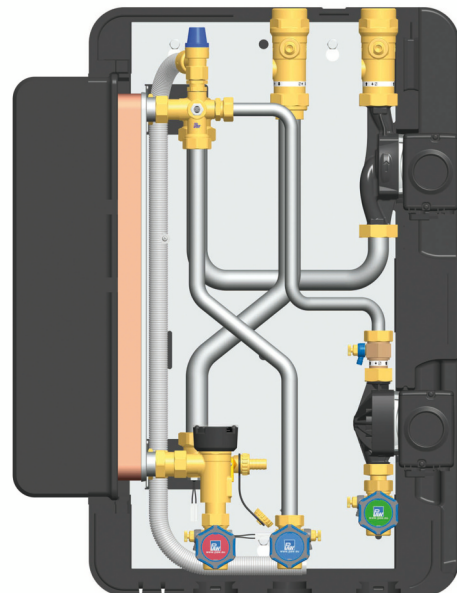

7.3 Adjustment of the temperature

Set the desired (maximal) domestic hot water temperature at the controller at "**Main menu / Hot water / Nominal temperature**" (see controller instructions, chapter *Hot water*).

WARNING



Danger of scalding due to hot water!

In order to avoid scalding at the tap, the maximum domestic hot water temperature must not exceed **60 °C**.

Recommendation for comfort optimisation: For high buffer tank temperatures (e.g. solar thermal system), the hot water temperature must be set as high as possible (max. 60 °C).

Primary side

The required temperature on the primary side in the buffer tank depends on the desired domestic hot water temperature and on the required tap quantity. The temperature in the buffer tank must be at least 5 K above the desired domestic hot water temperature.

Secondary side:

The possible withdrawal flow rate [l/min] at the tap depends on the domestic hot water temperature adjusted at the controller and on the temperature available in the buffer tank.

Due to the system, considerable modifications of the domestic water flow rate cause fluctuations of the hot water outlet temperature. These fluctuations are usually compensated by the piping network in the building or by adding cold water at the fittings.

The recommended maximum domestic hot water flow rate through the domestic hot water module **FriwaMidi** is 65 l/min. The flow rate of the **FriwaMaxi** 88 l/min.

7 Commissioning [specialist]

7.4 Maximum withdrawal flow rate FriwaMidi

Buffer tank temperature	Nominal temperature	max. output capacity*	Transmission performance	req. V_{tank} per litre of HW	for an inlet temperature of 10 °C (cold water temperature) - max. withdrawal quantity** at the mixing valve at				Return temperature
					40 °C	45 °C	50 °C	55 °C	
					45 °C	40 °C	34 l/min	71 kW	
50 °C	40 °C	44 l/min	93 kW	0.9 l	-	-	-	-	18 °C
	45 °C	32 l/min	79 kW	1.3 l	37 l/min	-	-	-	22 °C
55 °C	40 °C	53 l/min	111 kW	0.8 l	-	-	-	-	16 °C
	45 °C	42 l/min	102 kW	1.0 l	48 l/min	-	-	-	19 °C
	50 °C	31 l/min	87 kW	1.3 l	41 l/min	35 l/min	-	-	24 °C
60 °C	40 °C	61 l/min	128 kW	0.7 l	-	-	-	-	15 °C
	45 °C	50 l/min	121 kW	0.8 l	57 l/min	-	-	-	17 °C
	50 °C	40 l/min	111 kW	1.0 l	53 l/min	45 l/min	-	-	21 °C
	55 °C	30 l/min	95 kW	1.4 l	45 l/min	38 l/min	34 l/min	-	27 °C
65 °C	40 °C	65 l/min***	136 kW	0.6 l	-	-	-	-	14 °C
	45 °C	57 l/min	139 kW	0.7 l	66 l/min	-	-	-	16 °C
	50 °C	47 l/min	131 kW	0.9 l	62 l/min	53 l/min	-	-	19 °C
	55 °C	38 l/min	120 kW	1.1 l	57 l/min	49 l/min	43 l/min	-	23 °C
	60 °C	30 l/min	103 kW	1.4 l	49 l/min	42 l/min	36 l/min	32 l/min	29 °C
70 °C	40 °C	65 l/min***	136 kW	0.5 l	-	-	-	-	14 °C
	45 °C	63 l/min	155 kW	0.7 l	74 l/min	-	-	-	15 °C
	50 °C	53 l/min	149 kW	0.8 l	71 l/min	60 l/min	-	-	17 °C
	55 °C	45 l/min	141 kW	0.9 l	67 l/min	57 l/min	50 l/min	-	20 °C
	60 °C	37 l/min	130 kW	1.1 l	61 l/min	52 l/min	46 l/min	41 l/min	24 °C

Buffer tank temperature	Nominal temperature	max. output capacity*	Transmission performance	req. V _{tank} per litre of HW	for an inlet temperature of 10 °C (cold water temperature) - max. withdrawal quantity** at the mixing valve at				Return temperature
					40 °C	45 °C	50 °C	55 °C	
75 °C	40 °C	65 l/min***	136 kW	0.5 l	-	-	-	-	13 °C
	45 °C	65 l/min***	159 kW	0.6 l	75 l/min	-	-	-	15 °C
	50 °C	59 l/min	166 kW	0.7 l	79 l/min	67 l/min	-	-	16 °C
	55 °C	51 l/min	159 kW	0.8 l	76 l/min	65 l/min	56 l/min	-	19 °C
	60 °C	43 l/min	151 kW	1.0 l	72 l/min	61 l/min	53 l/min	47 l/min	22 °C
80 °C	40 °C	65 l/min***	136 kW	0.4 l	-	-	-	-	13 °C
	45 °C	65 l/min***	159 kW	0.5 l	75 l/min	-	-	-	14 °C
	50 °C	65 l/min	181 kW	0.6 l	86 l/min	74 l/min	-	-	15 °C
	55 °C	56 l/min	176 kW	0.7 l	84 l/min	72 l/min	63 l/min	-	17 °C
	60 °C	49 l/min	170 kW	0.9 l	81 l/min	69 l/min	60 l/min	53 l/min	20 °C
85 °C	40 °C	65 l/min***	136 kW	0.4 l	-	-	-	-	13 °C
	45 °C	65 l/min***	159 kW	0.5 l	75 l/min	-	-	-	13 °C
	50 °C	65 l/min***	181 kW	0.6 l	86 l/min	74 l/min	-	-	15 °C
	55 °C	61 l/min	193 kW	0.7 l	92 l/min	78 l/min	68 l/min	-	16 °C
	60 °C	54 l/min	187 kW	0.8 l	89 l/min	76 l/min	66 l/min	59 l/min	18 °C
90 °C	40 °C	65 l/min***	136 kW	0.4 l	-	-	-	-	12 °C
	45 °C	65 l/min***	159 kW	0.5 l	75 l/min	-	-	-	13 °C
	50 °C	65 l/min***	181 kW	0.5 l	86 l/min	74 l/min	-	-	14 °C
	55 °C	65 l/min***	204 kW	0.6 l	97 l/min	83 l/min	72 l/min	-	16 °C
	60 °C	58 l/min	203 kW	0.7 l	97 l/min	83 l/min	72 l/min	64 l/min	17 °C

Buffer tank temperature	Nominal temperature	max. output capacity*	Transmission performance	req. V _{tank} per litre of HW	for an inlet temperature of 10 °C (cold water temperature) - max. withdrawal quantity** at the mixing valve at				Return temperature
					40 °C	45 °C	50 °C	55 °C	
95 °C	40 °C	65 l/min***	136 kW	0.4 l	-	-	-	-	12 °C
	45 °C	65 l/min***	159 kW	0.4 l	75 l/min	-	-	-	13 °C
	50 °C	65 l/min***	181 kW	0.5 l	86 l/min	74 l/min	-	-	14 °C
	55 °C	65 l/min***	204 kW	0.6 l	97 l/min	83 l/min	72 l/min	-	15 °C
	60 °C	63 l/min	219 kW	0.7 l	104 l/min	89 l/min	78 l/min	69 l/min	16 °C

* The max. output capacity depends on the pressure drop on the primary side.

** The max. withdrawal quantity at the mixing valve depends on the length and the insulation of the pipes.

*** Max. flow rate: 65 l/min, with pressure drop of the Friwa of 1000 mbar (for hydraulic reasons, higher values are only partly possible, measuring limit of the flow rate sensor ~133 l/min)

How to read the table (example):

The temp. in the heating storage tank (primary) is 65 °C and the nominal hot water temp. set at the controller is 50 °C (secondary):

- With a storage temp. of 65 °C, a max. of 47 l of domestic water/minute can be heated to 50 °C.
- This withdrawal corresponds to a performance of 131 kW.
- In order to obtain 1 l (or 100 l) of hot water with a temp. of 50 °C, the heating buffer tank must contain 0.9 l (or 90 l) with a temp. of 65 °C.
- These 47 l of hot water/minute with 50 °C can be mixed with cold water (10 °C) at the tap (mixing valve) to obtain 53 l per minute with 45 °C.
- The primary return temp. for a withdrawal of 47 l of domestic hot water/minute is 19 °C.

7.5 Maximum withdrawal flow rate FriwaMaxi

Buffer tank temperature	Nominal temperature	max. output capacity*	Transmission performance	req. V _{tank} per litre of HW	for an inlet temperature of 10 °C (cold water temperature) - max. withdrawal quantity** at the mixing valve at				Return temperature	
					40 °C	45 °C	50 °C	55 °C		
					45 °C	40 °C	52 l/min	109 kW		1.2 l
50 °C	40 °C	68 l/min	143 kW	0.9 l	-	-	-	-	-	18 °C
	45 °C	50 l/min	122 kW	1.3 l	58 l/min	-	-	-	-	22 °C
55 °C	40 °C	82 l/min	172 kW	0.8 l	-	-	-	-	-	16 °C
	45 °C	65 l/min	158 kW	1.0 l	75 l/min	-	-	-	-	19 °C
	50 °C	48 l/min	135 kW	1.3 l	64 l/min	55 l/min	-	-	-	24 °C
60 °C	40 °C	88 l/min***	184 kW	0.7 l	-	-	-	-	-	15 °C
	45 °C	77 l/min	187 kW	0.8 l	89 l/min	-	-	-	-	17 °C
	50 °C	62 l/min	172 kW	1.0 l	82 l/min	70 l/min	-	-	-	21 °C
	55 °C	47 l/min	148 kW	1.4 l	70 l/min	60 l/min	52 l/min	-	-	26 °C
65 °C	40 °C	88 l/min***	184 kW	0.6 l	-	-	-	-	-	14 °C
	45 °C	88 l/min	214 kW	0.7 l	102 l/min	-	-	-	-	16 °C
	50 °C	73 l/min	203 kW	0.9 l	96 l/min	82 l/min	-	-	-	19 °C
	55 °C	59 l/min	187 kW	1.1 l	88 l/min	76 l/min	66 l/min	-	-	22 °C
	60 °C	46 l/min	160 kW	1.4 l	76 l/min	65 l/min	57 l/min	50 l/min	-	28 °C
70 °C	40 °C	88 l/min***	184 kW	0.5 l	-	-	-	-	-	14 °C
	45 °C	88 l/min***	215 kW	0.6 l	102 l/min	-	-	-	-	15 °C
	50 °C	83 l/min	230 kW	0.8 l	109 l/min	94 l/min	-	-	-	17 °C
	55 °C	70 l/min	218 kW	0.9 l	103 l/min	89 l/min	78 l/min	-	-	20 °C
	60 °C	58 l/min	201 kW	1.1 l	95 l/min	81 l/min	71 l/min	63 l/min	-	24 °C

7 Commissioning [specialist]

Buffer tank temperature	Nominal temperature	max. output capacity*	Transmission performance	req. V _{tank} per litre of HW	for an inlet temperature of 10 °C (cold water temperature) - max. withdrawal quantity** at the mixing valve at				Return temperature
					40 °C	45 °C	50 °C	55 °C	
75 °C	40 °C	88 l/min***	184 kW	0.5 l	-	-	-	-	13 °C
	45 °C	88 l/min***	215 kW	0.6 l	102 l/min	-	-	-	14 °C
	50 °C	88 l/min***	245 kW	0.7 l	116 l/min	100 l/min	-	-	16 °C
	55 °C	79 l/min	246 kW	0.8 l	117 l/min	100 l/min	88 l/min	-	18 °C
	60 °C	67 l/min	233 kW	1.0 l	111 l/min	95 l/min	83 l/min	74 l/min	21 °C
80 °C	40 °C	88 l/min***	184 kW	0.4 l	-	-	-	-	13 °C
	45 °C	88 l/min***	215 kW	0.5 l	102 l/min	-	-	-	14 °C
	50 °C	88 l/min***	245 kW	0.6 l	116 l/min	100 l/min	-	-	15 °C
	55 °C	87 l/min	273 kW	0.7 l	129 l/min	111 l/min	97 l/min	-	17 °C
	60 °C	75 l/min	262 kW	0.9 l	124 l/min	107 l/min	93 l/min	83 l/min	20 °C
85 °C	40 °C	88 l/min***	184 kW	0.4 l	-	-	-	-	12 °C
	45 °C	88 l/min***	215 kW	0.5 l	102 l/min	-	-	-	13 °C
	50 °C	88 l/min***	245 kW	0.6 l	116 l/min	100 l/min	-	-	15 °C
	55 °C	88 l/min***	276 kW	0.7 l	131 l/min	112 l/min	98 l/min	-	16 °C
	60 °C	83 l/min	289 kW	0.8 l	137 l/min	118 l/min	103 l/min	91 l/min	18 °C
90 °C	40 °C	88 l/min***	184 kW	0.4 l	-	-	-	-	12 °C
	45 °C	88 l/min***	215 kW	0.5 l	102 l/min	-	-	-	13 °C
	50 °C	88 l/min***	245 kW	0.5 l	116 l/min	100 l/min	-	-	14 °C
	55 °C	88 l/min***	276 kW	0.6 l	131 l/min	112 l/min	98 l/min	-	15 °C
	60 °C	88 l/min***	307 kW	0.7 l	146 l/min	125 l/min	109 l/min	97 l/min	17 °C

Buffer tank temperature	Nominal temperature	max. output capacity*	Transmission performance	req. V _{tank} per litre of HW	for an inlet temperature of 10 °C (cold water temperature) - max. withdrawal quantity** at the mixing valve at				Return temperature
					40 °C	45 °C	50 °C	55 °C	
95 °C	40 °C	88 l/min***	184 kW	0.4 l	-	-	-	-	12 °C
	45 °C	88 l/min***	215 kW	0.4 l	102 l/min	-	-	-	13 °C
	50 °C	88 l/min***	245 kW	0.5 l	116 l/min	100 l/min	-	-	14 °C
	55 °C	88 l/min***	276 kW	0.6 l	131 l/min	112 l/min	-	-	15 °C
	60 °C	88 l/min***	307 kW	0.6 l	146 l/min	125 l/min	109 l/min	97 l/min	16 °C

- * The max. output capacity depends on the pressure drop on the primary side. Assumption: 1 m wc. In the case of higher pressure drops, the maximum output capacity drops accordingly.
- ** The max. withdrawal quantity at the mixing valve depends on the length and the insulation of the pipes.
- *** Max. flow rate: 88 l/min, with pressure drop of the Friwa of 1000 mbar (for hydraulic reasons, higher values are only partly possible, measuring limit of the flow rate sensor ~133 l/min)

How to read the table (example):

The temp. in the heating storage tank (primary) is 65 °C and the nominal hot water temp. set at the controller is 50 °C (secondary):

- With a storage temp. of 65 °C, a max. of 73 l of domestic water/minute can be heated to 50 °C.
- This withdrawal corresponds to a performance of 203 kW.
- In order to obtain 1 l (or 100 l) of hot water with a temp. of 50 °C, the heating buffer tank must contain 0.9 l (or 90 l) with a temp. of 65 °C.
- These 73 l of hot water/minute with 50 °C can be mixed with cold water (10 °C) at the tap (mixing valve) to obtain 83 l per minute with 45 °C.
- The primary return temp. for a withdrawal of 73 l of domestic hot water/minute is 19 °C.

8 Maintenance

PAW domestic hot water modules are low in maintenance. Nevertheless, the following work needs to be carried out at regular intervals. For this, we recommend concluding a maintenance agreement with PAW GmbH & Co KG.

NOTICE

Hygiene recommendation

At temperatures below 60 °C, legionella bacteria can occur. After a longer downtime such as holidays, it is recommended to thoroughly flush all pipes for some minutes.

8.1 Inspection

The following table provides recommendations for the frequency of inspection activities.

Component	Check	Interval
Pipes	<ul style="list-style-type: none"> Visual inspection for leaks, corrosion and other damaging effects Check of the insulation For removable sections: check for stone formation or corrosion from the inside 	Annually
Heat exchanger (tightness of the partition walls)	<ul style="list-style-type: none"> Control of the system pressure on the primary side 	Semi-annually
Heat exchanger (stone formation)	<ul style="list-style-type: none"> Comparison of the set with the real hot water temperature 	Semi-annually
Noise generation	<ul style="list-style-type: none"> Check the station for critical noises during the tapping process, e.g. trapped air 	Semi-annually
Temperature / flow rate sensors	<ul style="list-style-type: none"> Comparison of the information on the display and plausibility check 	Semi-annually
Electronical components and plug connections	<ul style="list-style-type: none"> Check if the cable plug connections of all components are firmly in place and intact 	Semi-annually

8.2 Maintenance

The following table provides recommendations for the frequency of maintenance activities.

Component	Check	Interval
Pressure relief valve	<ul style="list-style-type: none"> • Check for leaks by manual actuation • Actuation of the venting device to ensure that the valve is not stuck or calcified • Check whether the valve closes automatically after actuation and the water drains off completely 	Semi-annually
Shut-off valves	<ul style="list-style-type: none"> • Check for mobility by opening and closing 	Annually
Return stratification valve	<ul style="list-style-type: none"> • Check the functionality by manually activating the relay in the menu "Automatic/manual mode" 	Semi-annually

Clean the station with a damp cloth without any detergent.

WARNING



Risk to life and limb due to hot fluids!

Depending on the conditions, temperatures of up to 95 °C can develop in the product and escape. There is a risk of burns!

- ▶ For all service, maintenance or repair work, make sure that you are equipped with the necessary protective equipment (gloves / goggles).
- ▶ Before service, maintenance or repair work, the product should be taken out of service and be cooled down.

9 Scope of delivery [specialist]

NOTICE

Serial number

Complaints and requests/orders of spare parts will only be processed with information on the serial number!

The serial number is placed on the support sheet of the station.

9.1 Spare parts control and insulation FriwaMidi

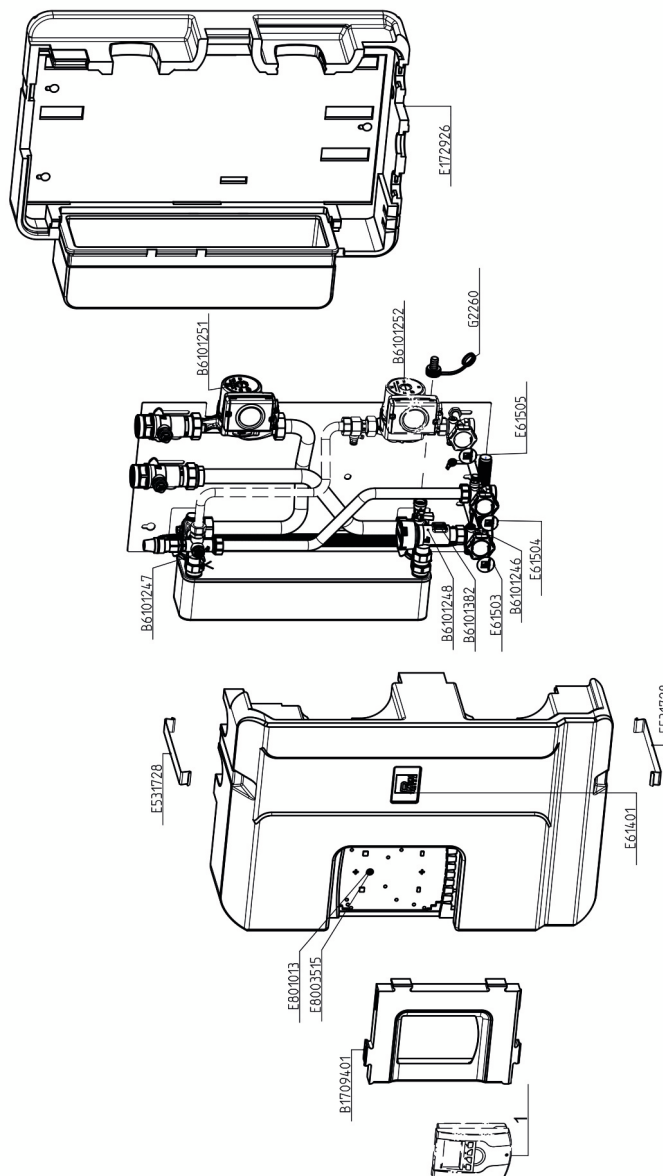

9.2 Spare parts hydraulics FriwaMidi

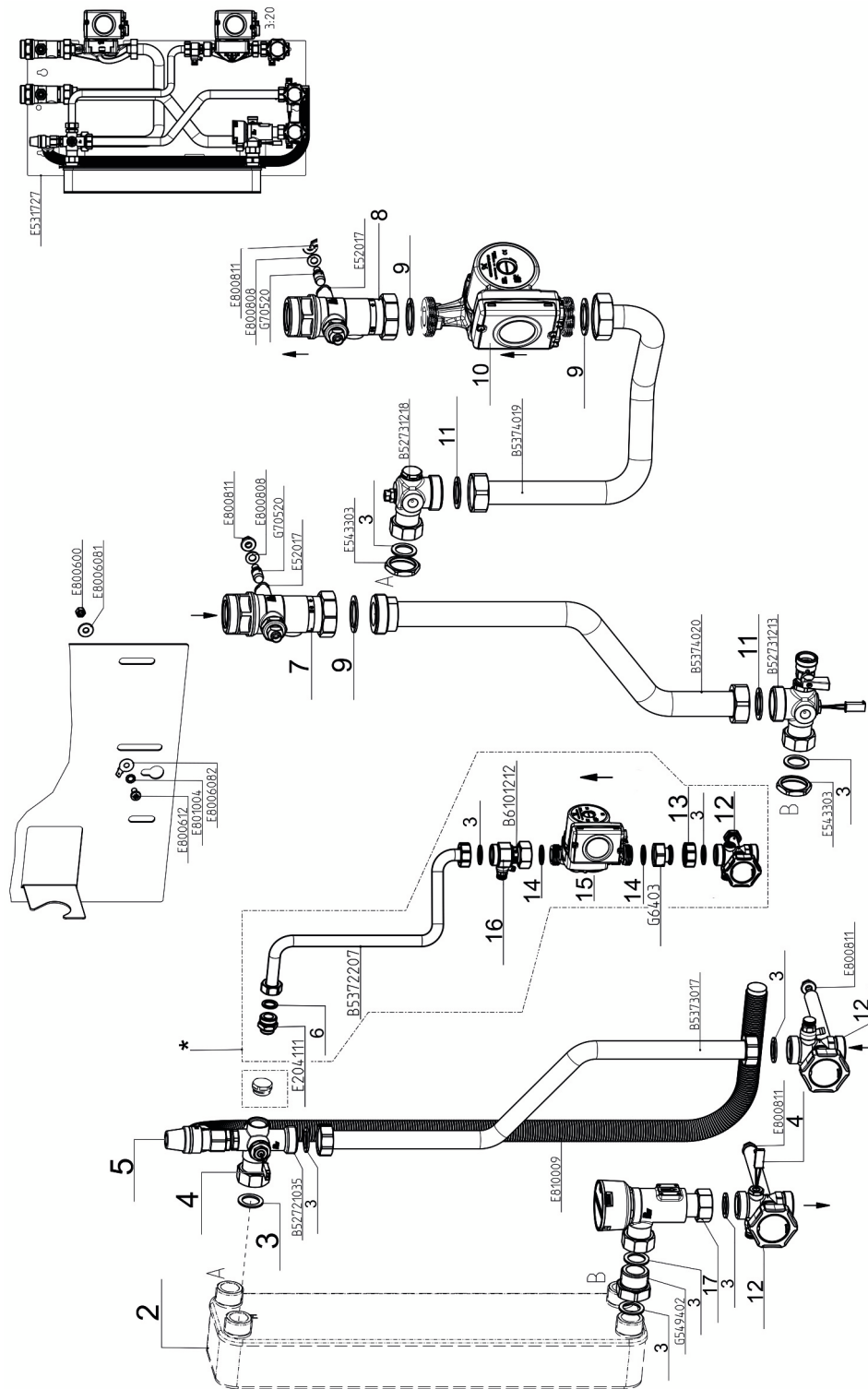

*only included in the scope of delivery of FriwaMidi with circulation

9 Scope of delivery [specialist]

9.3 Spare parts control and insulation FriwaMaxi

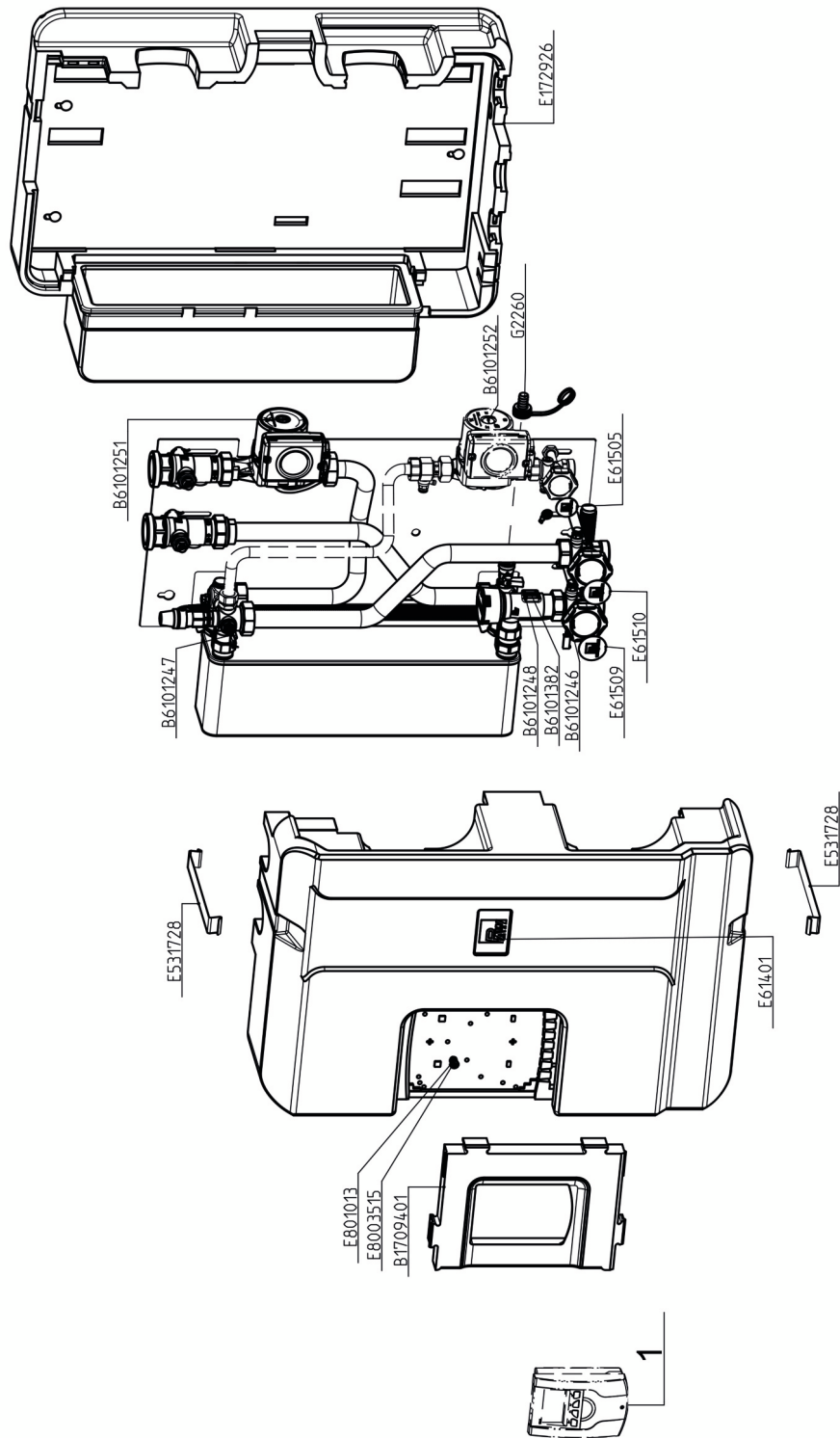

9.4 Spare parts hydraulics FriwaMaxi

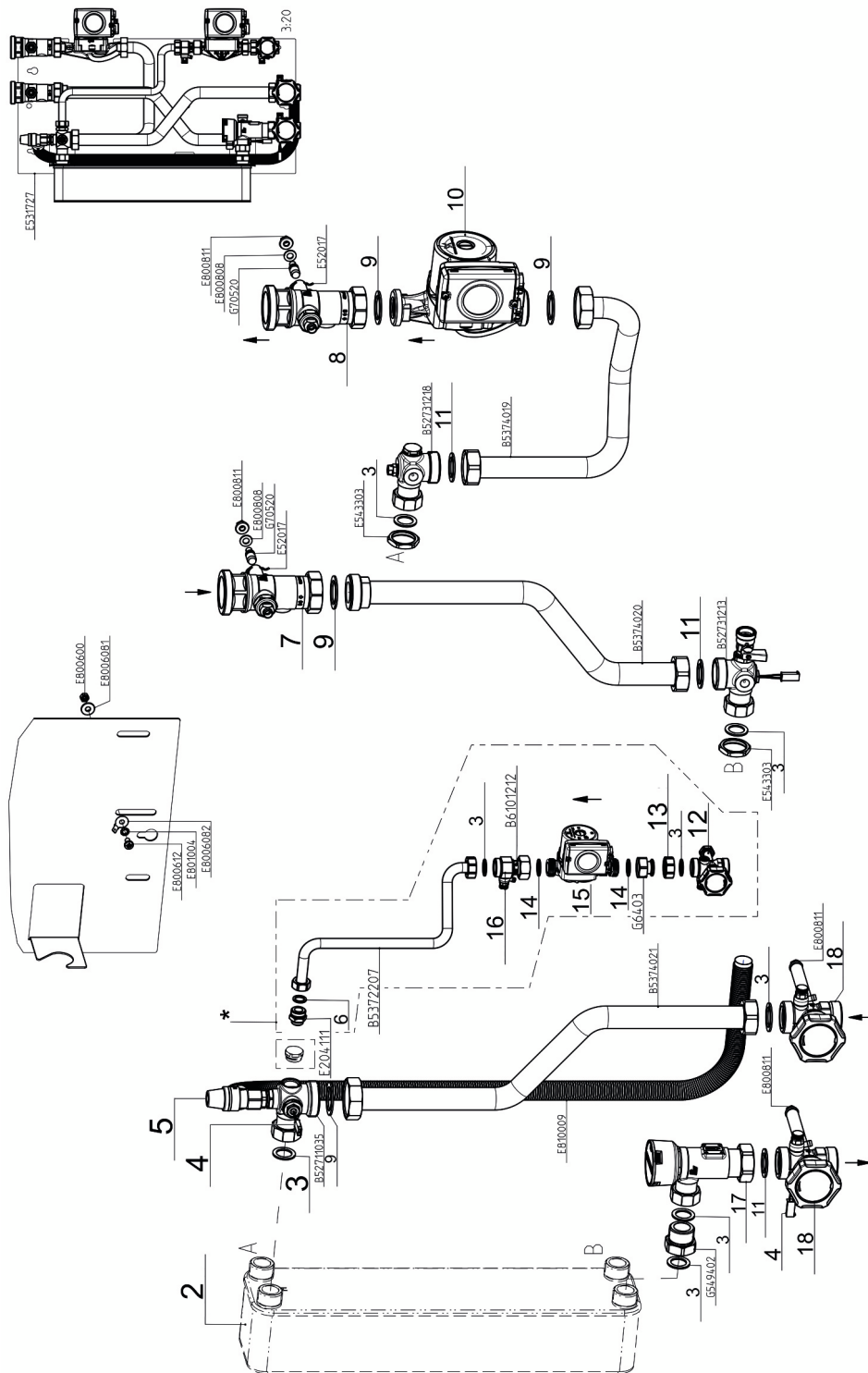

*only included in the scope of delivery of FriwaMaxi with circulation

9 Scope of delivery [specialist]

Position	Spare part	Item no.
1	Controller FC3.10	N00597
2	Heat exchanger, copper solder, with seals, for station 6405511 and 6405516	N00600
	Heat exchanger, copper solder, with seals, for station 6406511 and 6406516	N00601
	Heat exchanger, coated, with seals, for station 6405531 and 6405536	N00279
	Heat exchanger, coated, with seals, for station 6406531 and 6406536	N00281
3	Seal 30.0 x 21.0 x 2.0, ½", for thread connection 1", AFM, 10 pieces	N00024
4	Temperature sensor Pt1000-B, with connection cable	N00005
5	Pressure relief valve ½" x ¾", MSV 10 bar	N00008
6	Seal 24.0 x 17.0 x 2.0, ¼", for thread connection ¾", AFM, 10 pieces	N00030
7	Ball valve DN 32 with check valve at the flange, 1½" nut x 1½" ext. thread, 190 mm wc; for FriwaMidi	N00377
	Ball valve DN 32 with plastic check valve at the flange, 1½" nut x 2" ext. thread, 400 mm wc; for FriwaMaxi	N00364
8	Ball valve DN 32 with check valve at the head piece, 1½" nut x 1½" ext. thread, 190 mm wc; for FriwaMidi	N00378
	Ball valve DN 32 with plastic check valve at the head piece, 1½" nut x 2" ext. thread, 400 mm wc; for FriwaMaxi	N00365
9	Seal 44.0 x 32.0 x 2.0, 1", for thread connection 1½", AFM, 10 pieces	N00036
10	Primary pump Grundfos UPM2 25-75, with gaskets; for FriwaMidi	N00273
	Primary pump Grundfos UPML 25-105, with seals: for FriwaMaxi	N00274
11	Seal 38.0 x 27.0 x 2.0; ¾"; for thread connection 1¼", 10 pieces	N00174
12	Piston valve DN 20; 2x 1" ext. thread, blue handle, 1 x brass plug, with draining	N00211
13	Union nut G 1", passage 28.1 mm, wrench size 37, octagonal	N00302

Position	Spare part	Item no.
14	Seal 30.0 x 21.0 x 2.0, ½", for thread connection 1", EPDM, 10 pieces	N00129
15	Circulation pump Grundfos UPM2 15-75 CIL2, with seals	N00275
16	Non-return valve DN 20 for circulation line	N00283
17	FlowSonic DN 20, with seals, for FriwaMidi	N00276
	FlowSonic DN 25, with seals, for FriwaMaxi	N00277
18	Piston valve DN 25; 2x 1¼" ext. thread, blue handle, 1 x brass plug, with draining	N00574

10 Technical data

Station	FriwaMidi	FriwaMaxi
Dimensions		
Height (with insulation)	795 mm	
Width (with insulation)	602 mm	
Depth (with insulation)	298 mm	
Centre distance top	120 mm	
Centre distance bottom	100 mm	
Pipe connections		
Primary circuit (storage tank circuit)	1½" ext. thread	2" ext. thread
Secondary circuit (DHW circuit)	1" ext. thread, flat sealing	1¼" ext. thread, flat sealing
Secondary circuit (circulation)	1" ext. thread, flat sealing	
Operating data		
Max. admissible pressure	primary: 3 bar, secondary: 10 bar	
Operating temperature	2 – 95 °C	
Equipment		
Check valve	2 x 190 mm wc	2 x 400 mm wc
Primary pump	High-efficiency pump with PWM control, 3-70 W	High-efficiency pump with PWM control, 6-140 W
Secondary pump (optional)	High-efficiency pump with PWM control, 5-63 W	
Heat exchanger	40 plates	60 plates
Flow meter	FlowSonic, measuring range: 1-133 l/min	
Temperature sensor	3 x Pt1000, rapid	
Materials		
Valves and fittings	Brass	
Seals: o-rings	Klingersil / EPDM	
Flat seals	AFM34, asbestos-free	

Station	FriwaMidi	FriwaMaxi
Plate heat exchanger	uncoated: stainless steel 1.4401 / solder: 99.99% Cu coated: SiO ₂	
Insulation	EPP	
Check valve	Brass	

10 Technical data

10.1 Dimensional drawings

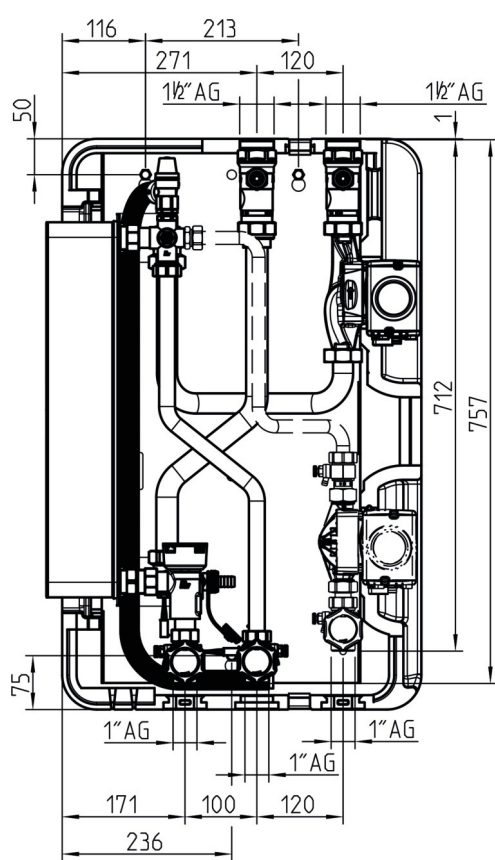
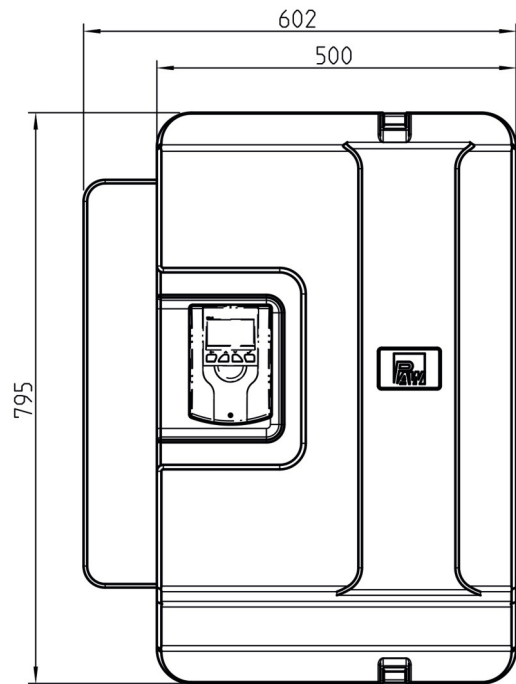
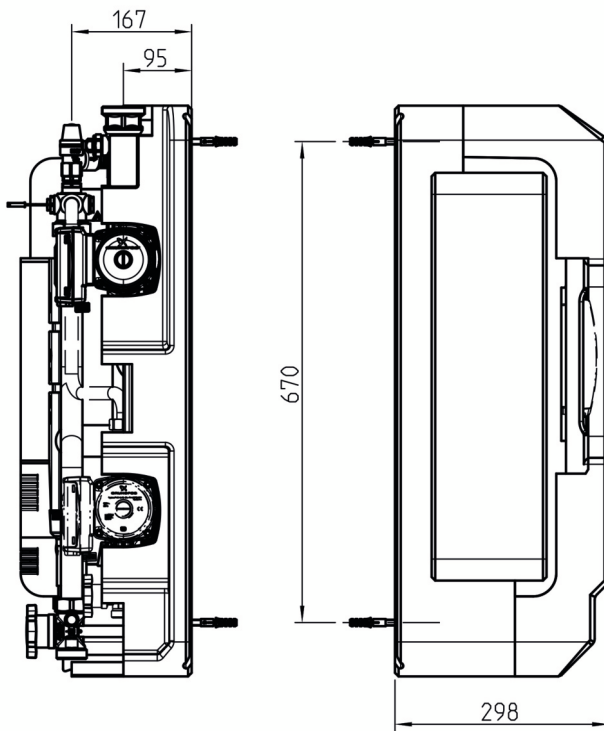

FriwaMidi

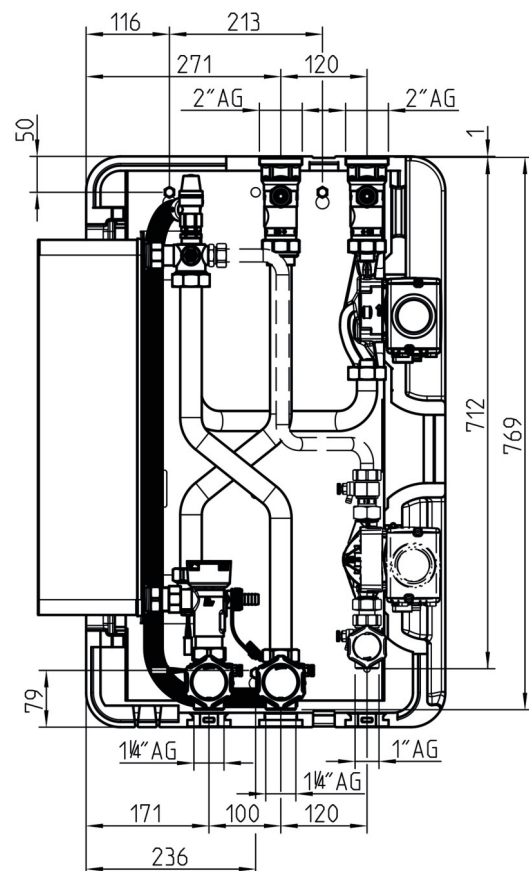

FriwaMaxi

10.2 Pressure drop and pump characteristic curves FriwaMidi

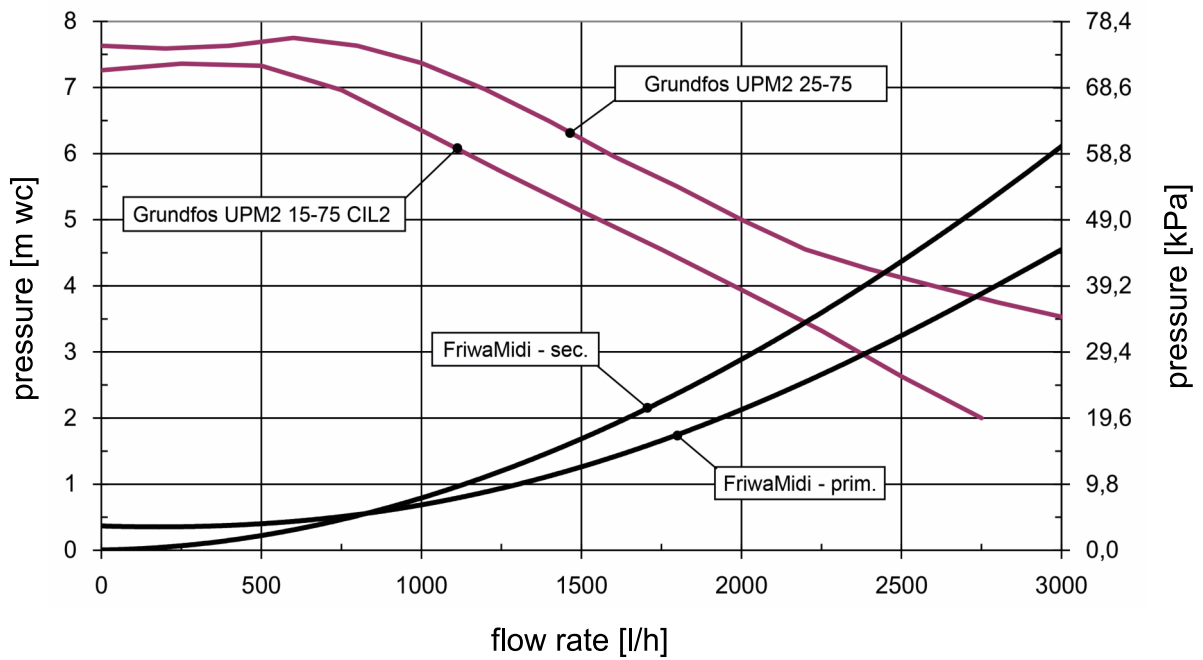

10.3 Pressure drop and pump characteristic curves FriwaMaxi

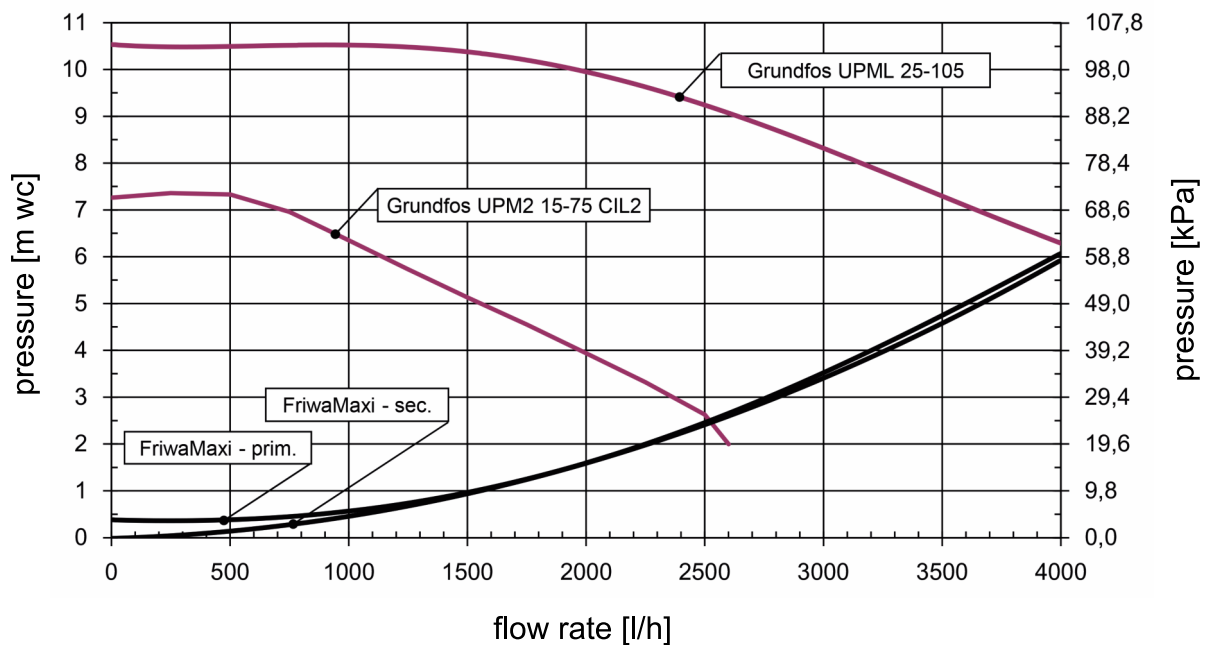

11 Disposal

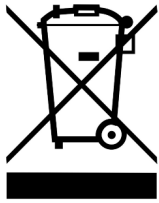
NOTICE	
	<p>Electrical and electronic devices must not be disposed of in the household waste.</p> <p>For your return, there are free collection points for electrical appliances and, if necessary, additional points of acceptance for the reuse of the devices in your area. The addresses can be obtained from your city or communal administration.</p> <p>If the old electrical or electronic device contains personal data, you are responsible for deleting it before returning the device.</p> <p>Batteries and rechargeable batteries must be removed prior to the disposal of the product. Depending on the product equipment (partly with optional accessories), single components can also contain batteries and rechargeable batteries.</p> <p>Please observe the disposal symbols on the components.</p>

Disposal of transport and packaging materials

The packaging materials are made of recyclable materials and can be disposed of with recyclable materials.

12 Commissioning report

System operator	
Location of installation	
Serial numbers:	
<ul style="list-style-type: none"> • Domestic hot water module 	
<ul style="list-style-type: none"> • Flow rate sensor 	
<ul style="list-style-type: none"> • Controller 	
<ul style="list-style-type: none"> • Software version 	
Pipes primary	Diameter = mm; Length = m
Pipes secondary	Diameter = mm; Length = m
Pipes circulation	Diameter = mm; Length = m
Other additionally installed components	Return distribution set
	Other
Have both circuits been flushed and vented correctly? (no air noises in the pump)	vented
Are all shut-off valves open in the cold water line?	open
Is there a pressure of at least 1.5 bars on the primary side?	checked
Is there a pressure of at least 2.5 bars on the secondary side?	checked
Is the potential equalisation processed according to regulations?	checked
Is there an error message on the display?	no message
Installation company	Date, signature



13 Notes





Item no. 99640x5xx-mub-en

Translation of the original instructions

We reserve the right to make technical changes without notice!

Printed in Germany – Copyright by PAW GmbH & Co. KG

PAW GmbH & Co. KG

Böcklerstraße 11

31789 Hameln, Germany

www.paw.eu

Phone: +49-5151-9856-0

Fax: +49-5151-9856-98