

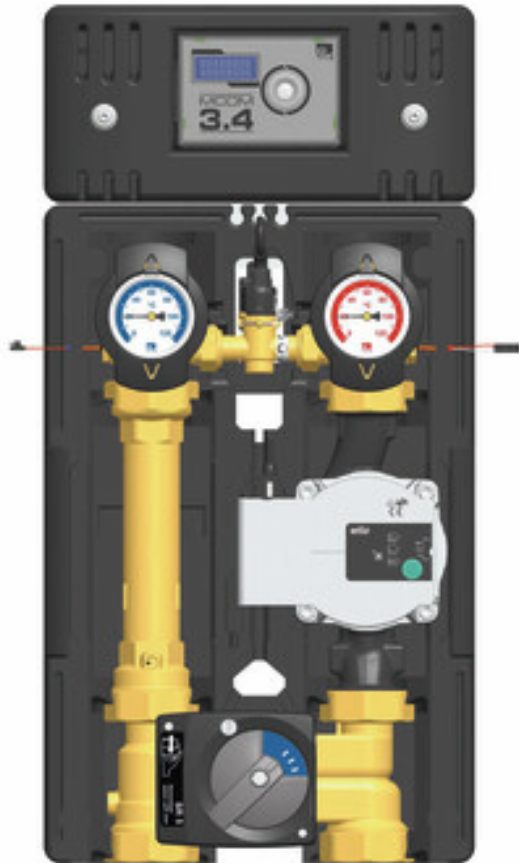

## Installation and Operation Instructions HeatBloC® MC45 - DN 25



## Table of Contents

<b>1</b>	<b>General Information.....</b>	<b>4</b>
<b>1.1</b>	<b>Scope of these instructions.....</b>	<b>4</b>
<b>1.2</b>	<b>Designated use.....</b>	<b>4</b>
<b>2</b>	<b>Safety instructions.....</b>	<b>5</b>
<b>3</b>	<b>Product description.....</b>	<b>6</b>
<b>3.1</b>	<b>Equipment.....</b>	<b>6</b>
<b>3.2</b>	<b>Function.....</b>	<b>7</b>
<b>3.3</b>	<b>3-temperature mixing valve [specialist].....</b>	<b>8</b>
<b>3.4</b>	<b>Pump [specialist].....</b>	<b>9</b>
<b>3.4.1</b>	<b>Pump settings Grundfos UPM3 Hybrid.....</b>	<b>9</b>
<b>3.4.2</b>	<b>Pump settings Wilo Para STG O / MAXO.....</b>	<b>10</b>
<b>3.5</b>	<b>Check valve and non-return valve.....</b>	<b>11</b>
<b>3.6</b>	<b>Assembly of the actuator.....</b>	<b>12</b>
<b>4</b>	<b>Change of the flow line [specialist].....</b>	<b>13</b>
<b>5</b>	<b>Mounting and installation [specialist].....</b>	<b>16</b>
<b>5.1</b>	<b>Installation and commissioning of the HeatBloC® .....</b>	<b>17</b>
<b>5.2</b>	<b>Cabling.....</b>	<b>20</b>
<b>5.3</b>	<b>Accessories.....</b>	<b>22</b>
<b>5.3.1</b>	<b>Connection set.....</b>	<b>22</b>
<b>5.3.2</b>	<b>Communication set.....</b>	<b>22</b>
<b>5.3.3</b>	<b>Accessories: Cutting-ring compression fitting (not included in the scope of delivery).....</b>	<b>23</b>
<b>5.3.4</b>	<b>Wall bracket set for wall assembly.....</b>	<b>23</b>
<b>5.3.5</b>	<b>Pipe sets for MC45.....</b>	<b>24</b>
<b>6</b>	<b>Maintenance [specialist].....</b>	<b>25</b>
<b>6.1</b>	<b>Disassembly of the strainer out of the differential pressure sensor (DPS).....</b>	<b>25</b>
<b>6.2</b>	<b>Installation of the strainer into the differential pressure sensor (DPS).....</b>	<b>27</b>
<b>7</b>	<b>Scope of delivery [specialist].....</b>	<b>29</b>
<b>7.1</b>	<b>Insulation and controller.....</b>	<b>29</b>

---

<b>7.2</b>	<b>Hydraulics.....</b>	<b>30</b>
<b>8</b>	<b>Technical data.....</b>	<b>32</b>
<b>8.1</b>	<b>Dimensional drawing DN 25.....</b>	<b>33</b>
<b>8.2</b>	<b>Pressure drop and pump characteristic curves.....</b>	<b>33</b>
<b>9</b>	<b>Disposal.....</b>	<b>34</b>

## 1 General Information



Carefully read these instructions before installation and commissioning.

Save these instructions in the vicinity of the installation for future reference.

### 1.1 Scope of these instructions

These instructions describe the installation, commissioning, functioning and the operation of a mixed HeatBloC®.

For other components of the installation, such as the pump, the controller or the modular distribution manifold, please observe the instructions of the corresponding manufacturer. The chapters called [specialist] are intended for specialists only.

### 1.2 Designated use

The product may only be used in heating circuits taking into consideration the technical limit values indicated in these instructions.

It must **not** be used in drinking water applications.

Improper usage excludes any liability claims.

This product complies with the relevant directives and is therefore labelled with the CE mark.

The Declaration of Conformity is available upon request, please contact the manufacturer.

Only use PAW accessories with the product.

## 2 Safety instructions

### 2 Safety instructions

The installation and commissioning as well as the connection of electrical components require technical knowledge commensurate with a recognised vocational qualification as a fitter for plumbing, heating and air conditioning technology, or a profession requiring a comparable level of knowledge [specialist].

The following must be observed during installation and commissioning:

- relevant local and national regulations
- accident prevention regulations of the professional association
- instructions and safety instructions mentioned in these instructions

#### CAUTION



#### Personal injury and damage to property!

The product must only be used in heating circuits filled with heating water according to VDI 2035 / Ö-Norm H 5195-1.

- ▶ The product must **not** be used in drinking water applications.

#### NOTICE

#### Material damage due to mineral oils!

Mineral oil products cause lasting damage to seals made of EPDM, whereby the sealant properties are lost. We do not assume liability nor provide warranty for damage to property resulting from sealants damaged in this way.

- ▶ It is imperative to prevent the EPDM sealing elements from making contact with substances containing mineral oils.
- ▶ Use a silicone- or polyalkylene-based lubricant free of mineral oil such as Unisilikon L250L and Syntheso Glep 1 from Klüber or a silicone spray.

### 3 Product description

The HeatBloC® is a preassembled group of fittings for heating circuits. The integrated pump can be isolated by means of the ball valves and can thus be maintained easily.

The nominal value for the differential pressure between the flow and the return is adjusted at the controller which actuates the pump on this basis. Thus, the hydraulic balancing at the distribution manifold is assured and an energy-saving operation of the pump is guaranteed at any time.

The PAW HeatBloC® must be either installed on a PAW modular distribution manifold or a PAW wall bracket.

For the function of a MC system, only **one** connection set (wall power supply, item no. 1398700) is necessary. The connection set is not included in the scope of delivery.

#### 3.1 Equipment

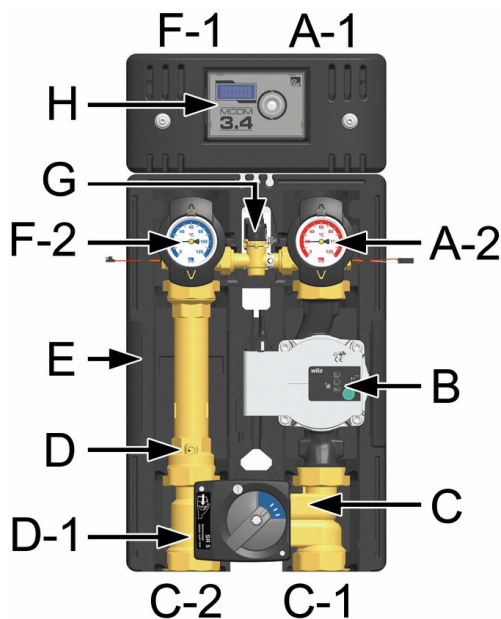

- A-1 Flow to the consumer circuit
- A-2 Flow ball valve with temperature sensor  $T_V$  and thermometer
- B Heating pump
- C 3-temperature mixing valve (4-way mixing valve)
- C-1 Flow from the heat generator
- C-2 Return to the heat generator
- D Return pipe with check valve (can be opened)
- D-1 Non-return valve, can be opened
- E EnEV-compliant design insulation
- F-1 Return from the consumer circuit
- F-2 Return ball valve with temperature sensor  $T_R$  and thermometer
- G Differential pressure sensor
- H Controller MCom

#### 3.2 Function

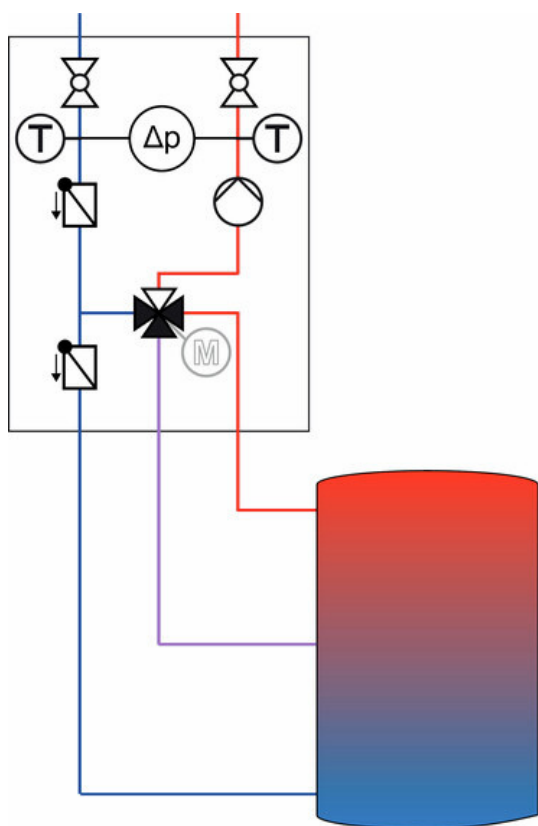

#### MC45 - 3-temperature mixing valve with additional connection for a second flow temperature

The 3-temperature mixing valve is used in combination with a buffer tank which can be heated either by a solar installation, a solid fuel boiler or a conventional boiler. The mixing valve is adjusted by means of an external controller.

If the consumer only needs a low temperature level, such as for radiant panel heating systems, the 3-temperature mixing valve first takes the flow water from the intermediate part of the storage tank. Only when the temperature in this part is no longer sufficient, the hot water from the upper part of the tank is used.

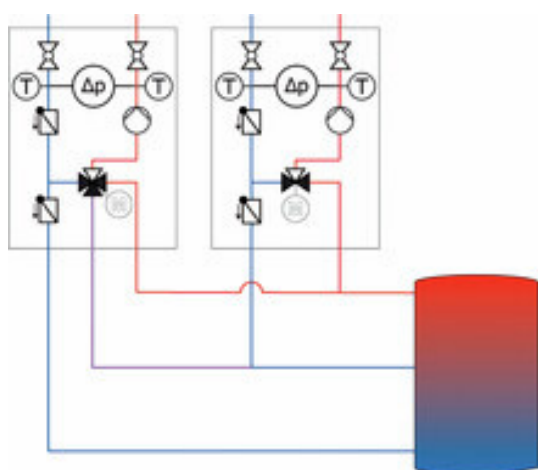

Assembly with radiator circuit (on the right) and radiant floor heating (on the left)

By using two parts of the storage tank for two different flow temperatures, the energy from the buffer tank can be used more efficiently. The return temperatures are low and the stratification in the buffer tank is maintained.

It is also possible to connect the return of a high-temperature heating circuit as the flow of a low-temperature heating circuit.

#### Application range:

- Heating systems with buffer tank and solar support
- Control of radiant floor heating and panel heating systems

### 3.3 3-temperature mixing valve [specialist]

The 3-temperature mixing valve, driven by an electric actuator, adjusts the flow temperature of the consumer circuit to the required value by means of the flow sensor and the controller.

The 3-temperature mixing valve is equipped with a second flow connection (C-3) on the back side. This connection allows to withdraw water with a lower flow temperature from the intermediate part of the tank, e.g. of a buffer tank.

**In case of K35:** A check valve is integrated in this second flow connection to avoid unwanted circulation in the mixing valve. This check valve is designed for heating pumps with a maximum head of 7 m. If you want to use a more powerful pump, an additional check valve may be necessary in the feed line.

**In case of MC45:** A non-return valve (D-1) prevents unwanted circulation.

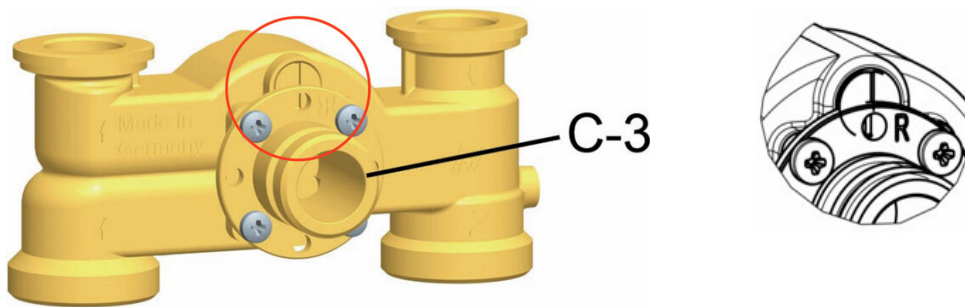

Rear view of mixing valve with flow on the right

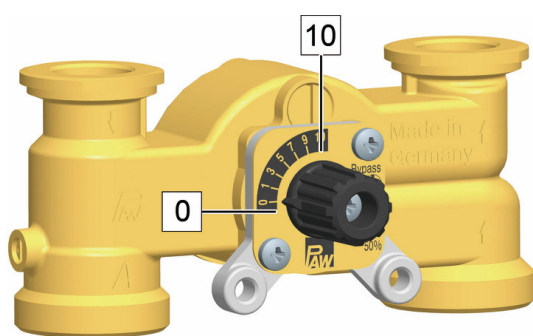

Expl. K35: Front view of mixing valve with flow on the right

**Position 0-5:**

The flow temperature is reached by mixing return water and water from the intermediate part of the tank.

**Position 5:**

100% supply from the intermediate part of the tank

**Position 5-10:**

The flow temperature is reached by mixing water from the intermediate part and the upper part of the tank.



### 3 Product description

#### 3.4 Pump [specialist]

The pump can be completely isolated. It can be replaced and maintained without draining the HeatBloC®s.

1. Close the ball valves in the flow and the return (A-2, F-2).
2. Remove the actuator from the mixing valve.
3. **Only regarding MC43 / MC44:** Turn the bypass screw of the mixing valve such that the slot is in a vertical position.
4. Turn the rotary knob of the mixing valve such that the black nose is directed to "VL zu" (flow closed).

In case of **MC43 / MC44** the black nose of the rotary knob points to the right (position "5 o'clock"). The mixing valve is now closed and drop tight.

**The pump has been correctly adjusted at the factory.** In the case of a breakdown of the control (no PWM signal), the pump runs at maximum rotation speed. To assure a proper functioning of the heating circuit, the pump must be set as follows:

- PWM profile (heating)

##### 3.4.1 Pump settings Grundfos UPM3 Hybrid

The following code must appear on the pump display. The code can be verified by briefly pressing the push button. Please observe the separate instructions of the pump.

- |   |          |
|---|----------|
| ⊗ | — Yellow |
| ○ | — Off    |
| ○ | — Off    |
| ⊗ | — Yellow |
| ⊗ | — Red    |



### 3.4.2 Pump settings Wilo Para STG O / MAXO

The pump settings are recognizable by glowing LEDs and must correspond to the following figure.

Please observe the separate instructions of the pump!

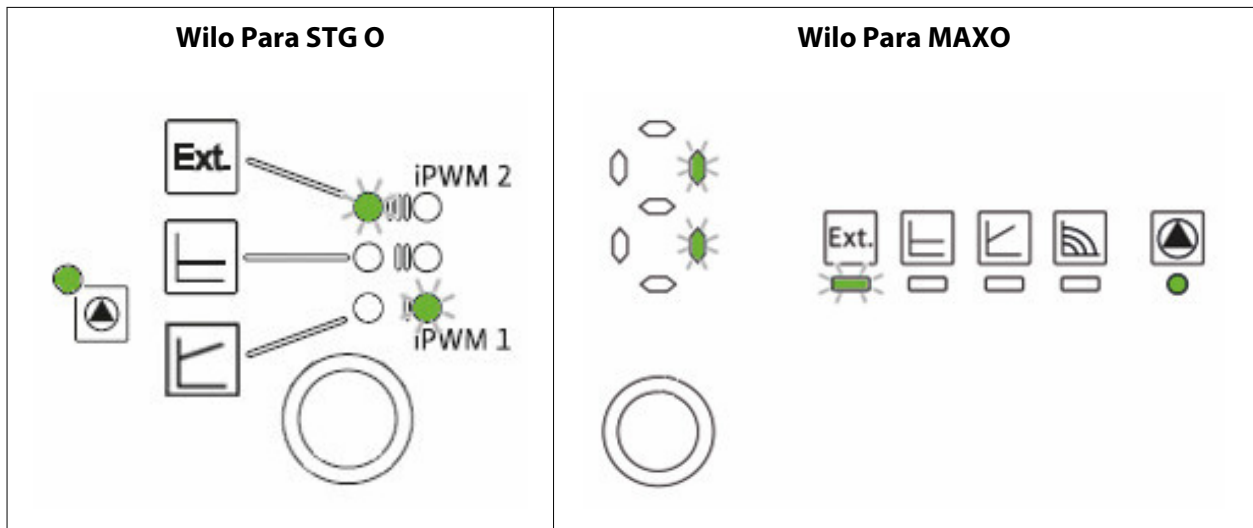

### 3 Product description

#### 3.5 Check valve and non-return valve

The product is equipped with a check valve and with a non-return valve. The valves can be opened.

##### operation

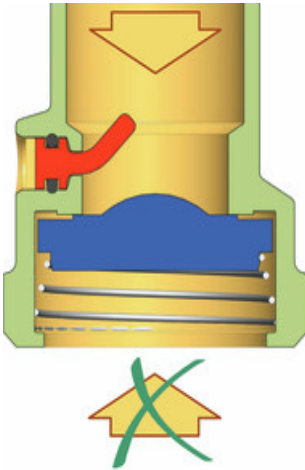

During operation, the markings must point to "Z".

- The check valve and the non-return valve are closed.
- Flow only in the direction of the arrow.

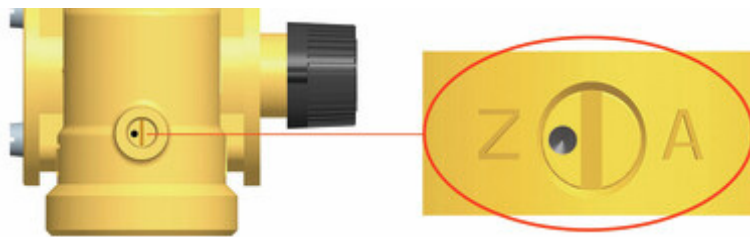

##### filling, draining, venting

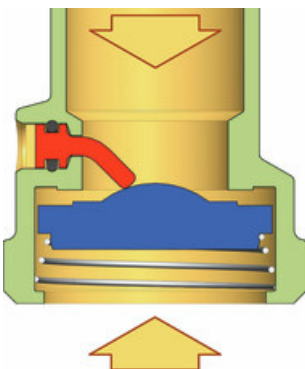

For filling, draining and venting, the markings must be directed to "A".

- The check valve and the non-return valve are closed.
- Flow in both directions.

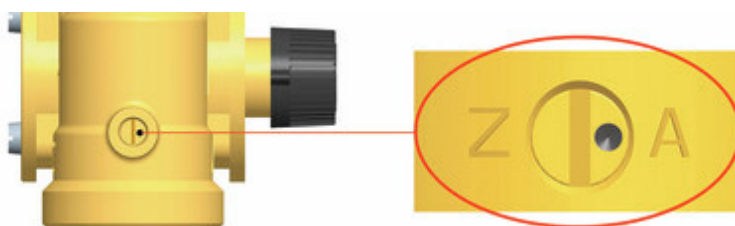

### 3.6 Assembly of the actuator

For mixing valves with flow on the left, the scale must be turned by 180°.

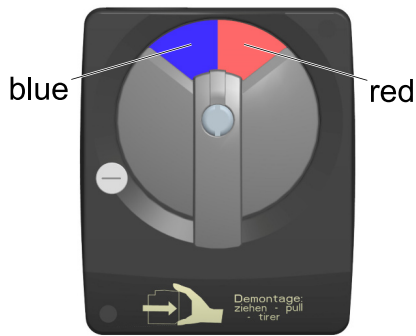

For mixing valve with flow on the right

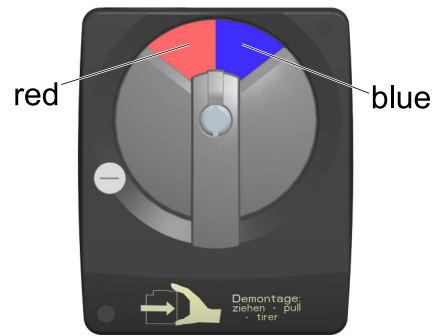

For mixing valve with flow on the left

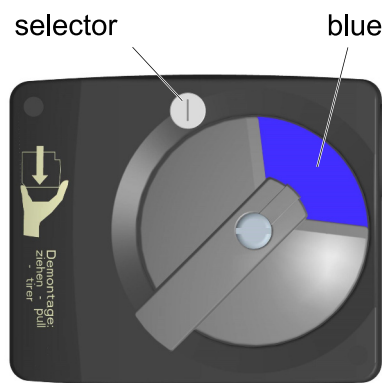

#### Assembly of the actuator - flow on the right:

1. Turn the rotary knob of the mixing valve into **Position 0**.
2. Set the actuator to manual mode by turning the selector switch.
3. Turn the rotary knob of the actuator to the left to the position shown on the adjacent figure.
4. Put the actuator on the adjusting knob of the mixing valve and the two stop bolts.
5. Set the actuator to automatic mode.



#### 4 Change of the flow line [specialist]

#### 4 Change of the flow line [specialist]

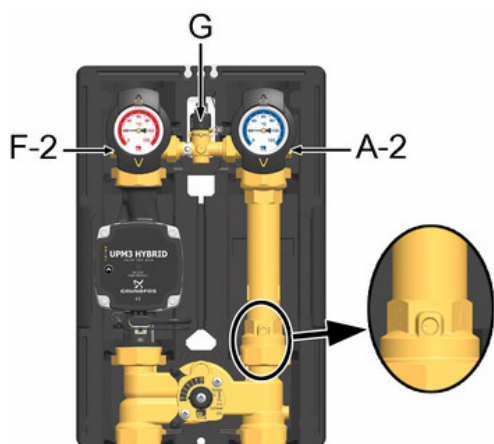

1. Dismount the temperature sensors of the ball valves (A-2 and F-2).
2. Unscrew both nuts of the sensor (G).
3. Unscrew the nuts above and beneath the pump or the return pipe.
4. Mount the return ball valve above the pump and the flow ball valve above the return pipe.

5. Dismount the mixing valve and retrofit it as described subsequently.
6. Interchange and mount the flow and return line. Please observe the position of the opening mechanism of the check valve in the return pipe (see figure).

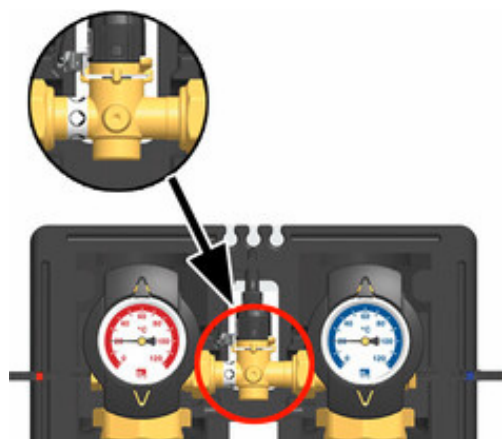

7. Mount the sensor (G) between the ball valves.

**Attention:** The ground lug points in the direction of the banderol.

The banderol indicates on which side of the sensor housing the pump must be fixed (see figure on the left).

8. Flatten the ground lug.

9. Mount the temperature sensors  $T_R$  and  $T_V$  in the ball valves. Observe the correct attribution: Red = Flow Blue = Return

10. Convert the actuator as described in chapter *Actuator*.

11. **Only MC42 and MC44:** Please observe the instructions of the boiler control manual when changing the flow line.

**Only MC43:** Change the direction of rotation of the actuator in the MCom controller. For this purpose, open the menu "Mixing valve" > "Direction" and set "Left". Please observe the separate instructions of the controller!

### Retrofitting of the mixing valve

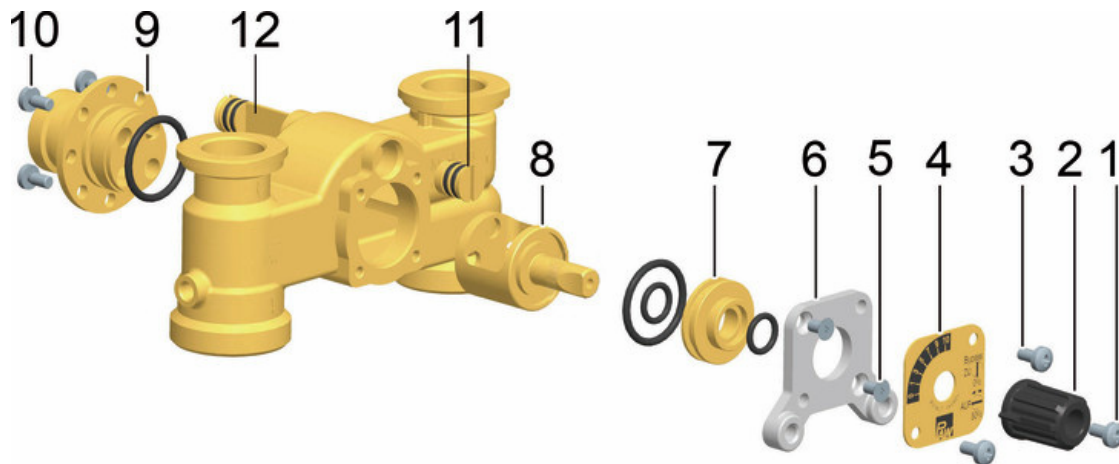

1. Loosen the screw (1).
2. Take off the rotary knob (2) from the cock rod.
3. Loosen the screws (3).
4. Remove the cover plate (4).
5. Loosen the two screws (5).
6. Remove the front plate (6).
7. Extract the sealing bush (7) with the cock plug (8) from the housing of the mixing valve.
8. Loosen the screws (10) on the back side of the mixing valve and take off the cover (9).
9. Pull the sealing plug (11) to the front by using pliers. Remove the flow-reducing plate (12) by pushing from front to back.
10. Turn the housing of the mixing valve by 180°.
11. Mount the flow-reducing plate (12) on the back side and the sealing plug (11) on the front side.

#### 4 Change of the flow line [specialist]

- Mount the cover (9) on the back side of the mixing valve. The letters on the cover indicate the correct assembly position:

flow on the left: L points upwards

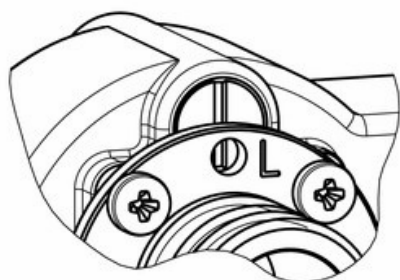

flow on the right: R points upwards



Assembly position for mixing valve with flow on the left

Assembly position for mixing valve with flow on the right

- Fix the cover (9) by using the screws (10).
- Insert the sealing bush (7) with the cock plug (8) into the channel of the mixing valve.
- Screw down the front plate (6) using the screws (5).



Flow

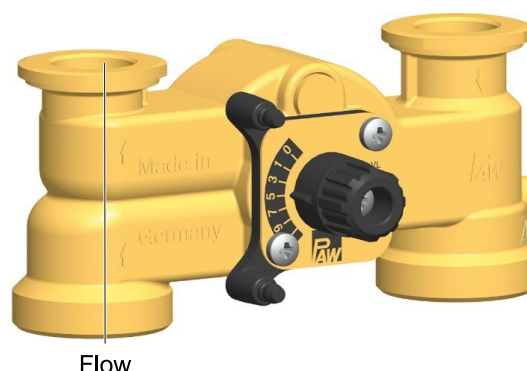

Flow

Mixing valve with flow on the right

Mixing valve with flow on the left

- Turn the cover plate (4) in such a way that the marking PAW is at the bottom and that the scale is positioned as shown in the figure above.
- Fix the cover plate (4) by using the screws (3).
- Put the rotary knob (2) onto the cock rod.
- Fix the rotary knob (2) on the cock plug (8) by using the screw (1).

## **5 Mounting and installation [specialist]**

The HeatBloC® can either be mounted on a distribution manifold or on a wall bracket. The distribution manifold and the wall bracket are optional accessories and are thus not included in the scope of delivery.

### **NOTICE**

#### **Damage to property!**

The installation site must be dry, stable, frost-proof and protected against ultraviolet radiation in order to prevent material damage of the installation.



## 5 Mounting and installation [specialist]

### 5.1 Installation and commissioning of the HeatBloC®

The HeatBloC® can be mounted on a PAW modular distribution manifold (not included in the scope of delivery).

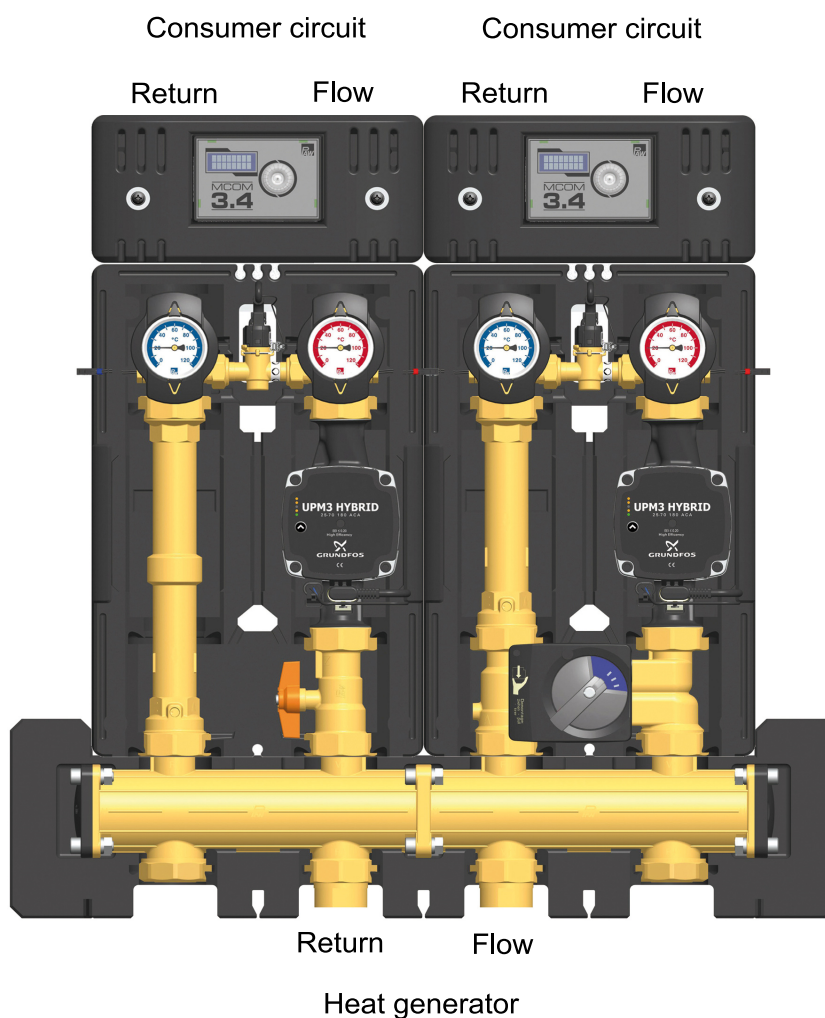

#### NOTICE

- ▶ Verify if the grounding cable holds securely in place at the differential pressure sensor!  
The ground lug points in the direction of the banderol.
- ▶ Carry out the following mounting instructions in parallel at each heating circuit of the system.

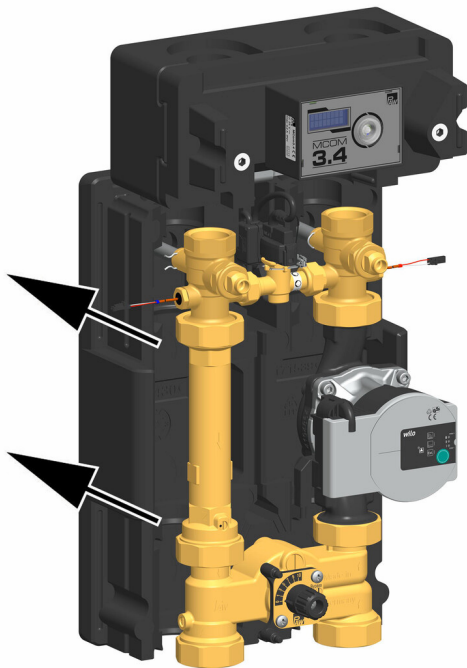

1. Remove the station from the packaging.
2. Take off the thermometer handles.
3. **Note regarding the HeatBloC® with Wilo pump:**

Dismount the insulating front shell of the controller and push the insulating back shell backwards.

4. Remove the actuator.
5. Take off the insulating front shells.
6. Push the insulating back shell backwards.

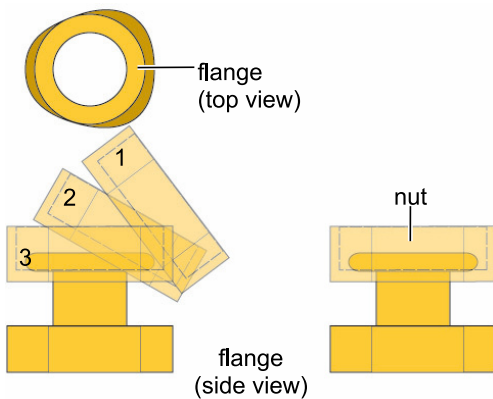

7. Unscrew the nuts on the lower connections of the HeatBloC® and take out the sealing rings.
8. Put the two nuts over the flanges of the distribution manifold.

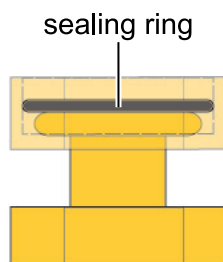

9. Put the sealing rings on the sealing surfaces.
10. Put the HeatBloC® onto the two sealing rings.
11. Tighten the nuts.

Make sure that the nuts do not get jammed and that the sealing rings do not slip.



12. Connect the HeatBloC® to the installation by using the pipes. The installation to the piping must be carried out without any tension.
 

**Only MC45:** The rear connection can be accessed from below.
  13. Repeat these steps for all the HeatBloC®s that are mounted.
  14. Fill and vent the installation.
  15. Carry out a pressure test and check all thread connections.
16. Check the position of the check valve. During operation, the marking must be point to "Z" (see chapter *Check valve*).
  17. Mount the insulating back shell.
 

**Only MC45:** In case that the optional pipe set is mounted to the rear connection (C-3), make sure that the plastic cap is correctly positioned.
  18. Run first the cable of the actuator through the insulating element of the mixing valve backwards. Mount the insulating element. Mount the actuator and pull the actuator cable lightly backwards at the same time.
  19. Connect the power supply of the pump and the actuator (only MC42 and MC44 / MC45) to the heating controller.
  20. **Only MC42-44:** Flush the installation.
  21. Mount the insulating front elements.
  22. Mount the insulating front and back shell of the distribution manifold.
 

**Note regarding only MC45:** Cut the insulating back shell in the pipe axis of the connection on the back of the mixing valve (C-3). The back shell of the distribution manifold is thus easier to mount.

## 5.2 Cabling

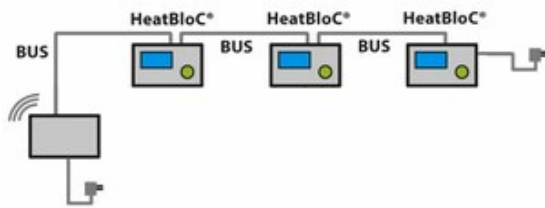

1. **For DN 25 / 32:** Loosen the screws of the controller insulation and dismount the insulating front shell of the controller.

**For DN 40 / 50:** Connect the actuator (only MC43), the temperature sensors (only MC41) and the differential pressure sensor to the controller (see below).

2. Connect the wall power supply to the socket X6.2 (see below) at the last (right) controller.
3. Connect the bus line from controller 1 to controller 2 in the socket X6.1. As the two sockets of the bus line (X6.1 and X6.2) are connected in parallel, the position has no importance.
4. Repeat these steps for all HeatBloC®s.
5. Remove the bus line from the first controller. Keep the bus line as spare part.

X1	<b>Only MC43 DN 25 / 32:</b> Signal of the actuator	X4	Temperature sensor $T_v$ , flow, red marking
X2	PWM signal of the pump	X5	Differential pressure sensor
X3	Temperature sensor $T_R$ , return, blue marking	X6.1	Supply voltage or bus line
		X6.2	(connected in parallel and therefore interchangeable)

## 5 Mounting and installation [specialist]

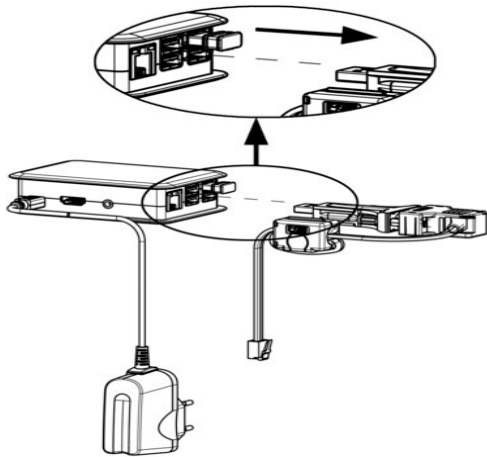

6. If you do not mount the optional communication set, continue with point 10.
7. If you additionally mount the optional communication set, run the bus line of the communication set to the first (left) controller. For this purpose, disconnect the plug of the bus line from the mini PC of the communication set.
8. Make sure that the plug does not get wet.
9. Mount the optional communication set now. Please observe the separate instructions of the communication set!
10. Carry out the electrical commissioning of the controllers (see controller instructions).
11. Carry out the electrical commissioning of the communication set (see instructions of the communication set).
12. Mount the insulating front shell of the controller.
13. Screw the screws in the controller insulation.
14. **For DN 40 / 50:** Mount the insulating front and back shells of the HeatBloC®s.
15. **For DN 40 / 50:** Mount the handles and insert the thermometers.
16. **For DN 40 / 50:** Mount the insulating front and back shell of the distribution manifold.
17. Please fill in the enclosed insert and fix it on the insulation.

HeatBloC® MC	
Typ:	<input type="text" value="MC41"/>
Name:	<input type="text" value="Storage tank"/>
No.:	<input type="text" value="2"/>
 <a href="http://www.paw.eu">www.paw.eu</a>	

- Type: Type of the heating circuit, e.g. MC41
- Name: Type of application, e.g. storage tank charging
- No.: Number of the heating circuit according to the controller instructions, e.g. 2

### 5.3 Accessories

#### 5.3.1 Connection set

For the connection of the MCom controllers to the power supply is mandatory **one** connection set (wall power supply, item no. 1398700), regardless of the number of heating circuits. The connection set is not included in the scope of delivery.

#### 5.3.2 Communication set

The communication set with insulated housing can be mounted on the distribution manifold or on the wall using the enclosed mounting rail. It is connected with the controllers via a bus line. The internal mini PC is equipped with a power supply unit to assure the power supply and establishes its own local WLAN network. With a smartphone and the corresponding PAW Connect app, you can establish a connection with your installation via this WLAN and set parameters or read out current values. You can receive the app in the App Store for iOS devices and in the Google Play Store for Android devices entering the search term "PAW Connect"

The Communication set is not included in the scope of delivery.

## 5 Mounting and installation [specialist]

### 5.3.3 Accessories: Cutting-ring compression fitting (not included in the scope of delivery)

The connection to the heating installation can be carried out fast, pressure-proof and without soldering if you use the optionally available compression fittings.

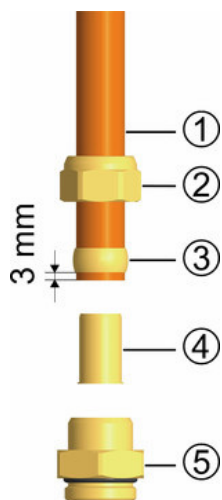

Not included in the scope of delivery!

1. Push the union nut ② and the cutting ring ③ onto the copper pipe ①. The pipe must protrude at least 3 mm from the cutting ring in order to ensure the force transmission and the sealing.
2. Insert the support sleeve ④ into the copper pipe.
3. Insert the copper pipe with the plugged-on individual parts ②, ③ and ④ as far as possible into the body of the compression fitting ⑤.
4. First, screw the union nut ② manually.
5. Tighten the union nut ② by rotating one full turn. Secure the body of the compression fitting ⑤ against distort in order to avoid damaging the sealing ring.

### 5.3.4 Wall bracket set for wall assembly

	<b>Description</b>	<b>Item no.</b>
	Wall bracket set DN 25	3422SET
	Wall bracket set DN 32	3722SET

Please observe the separate instructions. The wall bracket set is not included in the scope of delivery.

5.3.5 Pipe sets for MC45

	Description	Item no.
	Piping for a single HeatBloC® MC45	36092KS4
	Piping for two HeatBloC®s MC45	36092KS2
	Extension pipe set for three HeatBloC®s MC45	36092KS3

Please observe the separate instructions. The pipe sets are not included in the scope of delivery.



## 6 Maintenance [specialist]

### 6.1 Disassembly of the strainer out of the differential pressure sensor (DPS)

#### NOTICE

A maintenance of the differential pressure sensor may be necessary in different time intervals. The duration of the time interval depends on the quality of the heating water. A maintenance is necessary no later when the measurements of the differential pressure sensor vary strongly and a stable regulation of the pump is no longer possible.

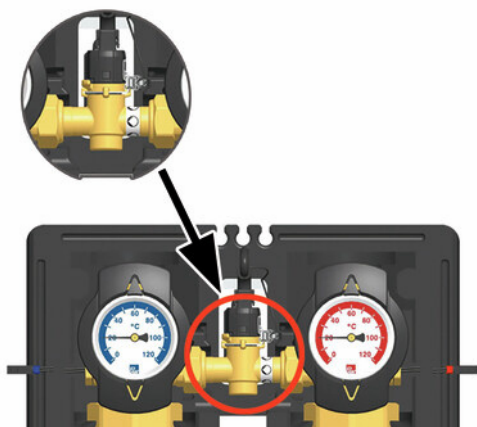
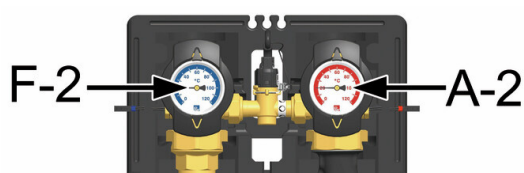

1. Shutdown the communication set (item no. 1398731), if existing (see instructions of the communication set). Switch off the system.
2. Shut off the MCom heating groups:
  - Return ball valve (F-2)
  - Flow ball valve (A-2)
3. Also, shut off the generator circuit (expansion tank, heat generator, storage tank).
4. Dismount the measuring point (see adjacent figure) of the differential pressure sensor.



5. Dismount the differential pressure sensor by removing the flat plug from the clip. The flat plug is equipped with a clamp spring. Press it in before removing the flat plug.
6. Finally remove the clip laterally out of the fitting.
7. Pull the differential pressure sensor upwards. If the sealing cap remains in the fitting, try to remove the sealing cap carefully and without any sharp objects, e.g. a screwdriver, out of the fitting. If the sealing cap is stuck on the sensor, remove it carefully.

**CAUTION**



**Damage to property at the sensor!**

The sensor element must not be penetrated by no means as this destroys the sensor and exchange costs won't be accepted.

- ▶ Clean the sensor with a damp cloth only.
- ▶ Check and clean the sealing cap of the sensor carefully without using any sharp objects e.g. a screwdriver.

8. Check and clean the brass fitting - **not the sensor!** - until a free passage is visible.

## 6.2 Installation of the strainer into the differential pressure sensor (DPS)

The installation is carried out in reverse order:



1. Put the new sealing cap on the sensor. The two bulges (see circle) must point towards the pump side.

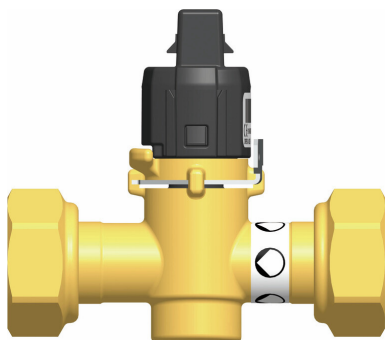

2. Introduce the sensor into the brass fitting until it is seated completely in the fitting. The direction of installation is predetermined by the fitting.
3. Fasten the sensor over the clip as shown in the illustration.
4. Insert the flat plug on the clip again.

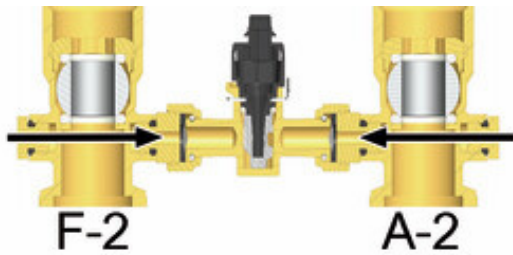

5. Put the brass fitting with the new sealings between the ball valves F-2 and A-2.

**Attention:** The sticker with the pump symbol must point to the pressure side, see illustration.

6. Put the installation into operation again:

- Open the previously closed ball valves and check the tightness of the measuring point of the differential pressure sensor.
- Check if the differential pressure sensor provides comprehensible values. For this, test the pump in the manual mode (see manual for MCom controller).

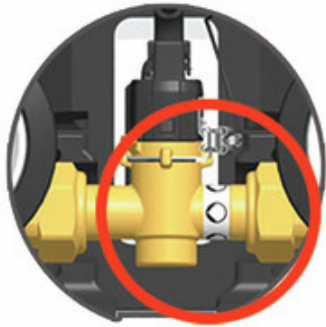

7. Set the MCom controller to automatic operation mode.
8. Note the maintenance works in your maintenance report.

## 7 Scope of delivery [specialist]

### NOTICE

#### Serial number

Complaints and requests/orders of spare parts will only be processed with information on the serial number! The serial number is placed on the return pipe of the product.

#### 7.1 Insulation and controller

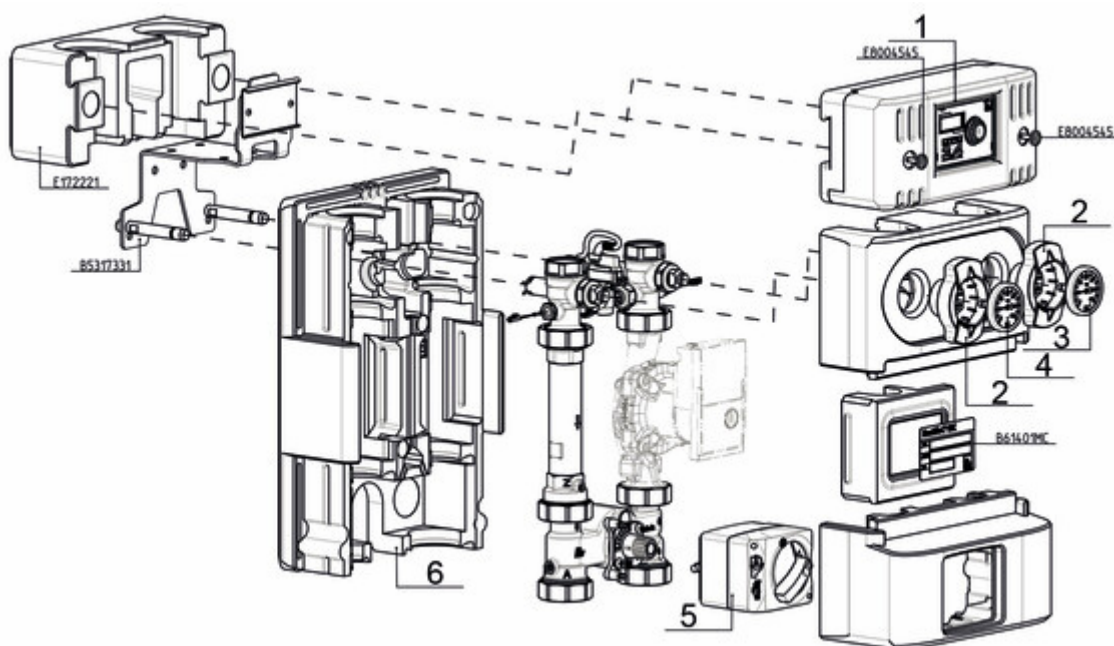

7.2 Hydraulics

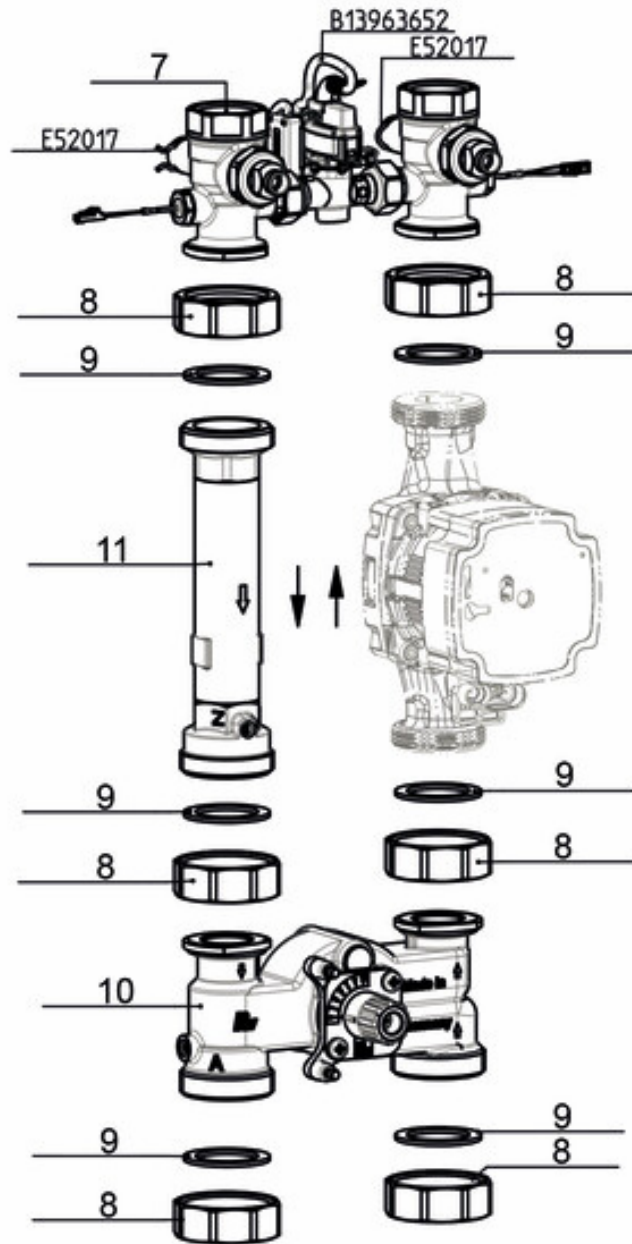

Position	Spare part	Item number
1	Controller MCom 3.4	N00143
2	Thermometer handle for ball valve 1" + 1¼"	N00248
3	Dial thermometer, red, d = 50 mm, 0 - 120 °C	N00242
4	Dial thermometer, blue, d = 50 mm, 0 - 120 °C	N00243
5	Actuator SR5, 230 V / 50 Hz, 5 Nm, 140 s / 90°	705001

## 7 Scope of delivery [specialist]

Position	Spare part	Item number
6	Insulation HeatBloC® DN 25	N00016
7	Thermometer ball valve DN 25, flange 1" x 1" int. thread	N00244
8	Union nut G1½", wrench size 52, octagonal	N00269
9	Sealing kit, 44.0 x 32.0 x 2.0, 1", for thread connection 1½", 10 pieces	N00131
10	3-temperature mixing valve DN 25, flange F1" x 1½" ext. thread, with non-return valve	B340616
11	Brass pipe DN 25, 2x 1½" ext. thread, 180 mm, with check valve and seals	N00018
no pos.	Sealing set for mixing valve	37013

Item no. heating circuit	Pump	Item no. pump	EEl
4536093MGU7	Grundfos UPM3 Hybrid 25-70	N00156	< 0.20
4536093MWS08	Wilo Para STG 25/8-60/O	N00457	< 0.20

**8 Technical data**

HeatBloC® MC45		DN 25 (1")
<b>Dimensions</b>		
Centre distance		125 mm
Width insulation		250 mm
Height insulation		500 mm
Installation length		340 mm
<b>Connections</b>		
Connection consumer		1" int. thread
Connections generator		1½" ext. thread, flat-sealing
<b>Operating data</b>		
Max. pressure		6 bar
Max. temperature		110 °C
K <sub>VS</sub> value [m <sup>3</sup> /h]	100 % return	5.1
	100% Low-temperature flow	4.1
	100% High-temperature flow	4.7
Opening pressure check valve		200 mm wc, can be opened
<b>Materials</b>		
Valves and fittings		Brass
Seals		AFM34 / EPDM
Insulation		EPP, EnEV compliant



## 8 Technical data

### 8.1 Dimensional drawing DN 25

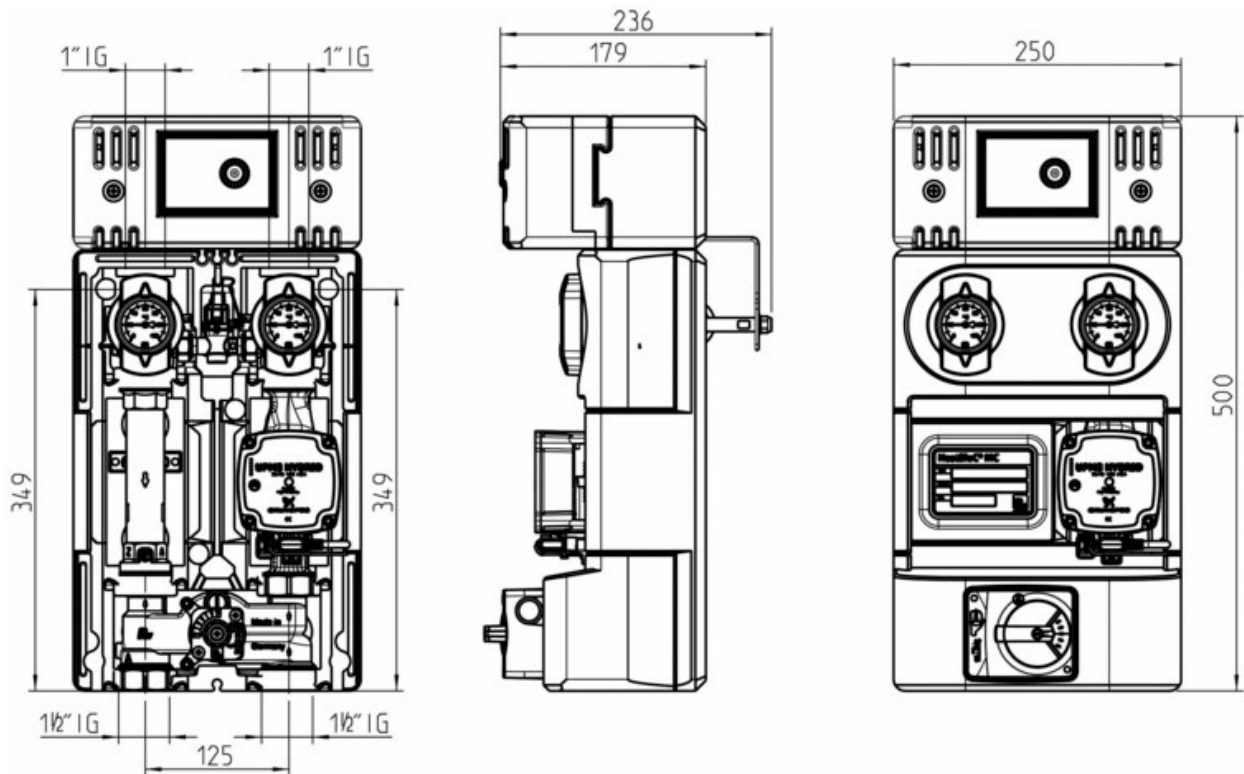

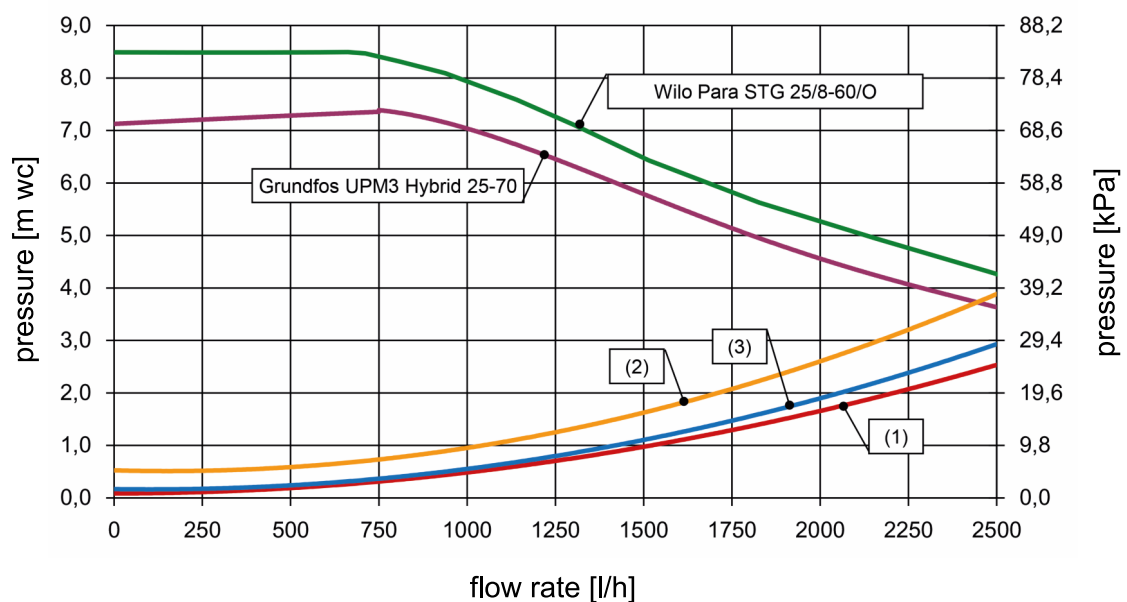

### 8.2 Pressure drop and pump characteristic curves

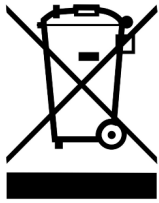

(1): 100% return (2): 100% low-temperature flow (3): 100% high-temperature flow

## 9 Disposal

NOTICE	
	<p>Electrical and electronic devices must not be disposed of in the household waste.</p> <p>For your return, there are free collection points for electrical appliances and, if necessary, additional points of acceptance for the reuse of the devices in your area. The addresses can be obtained from your city or communal administration.</p> <p>If the old electrical or electronic device contains personal data, you are responsible for deleting it before returning the device.</p> <p>Batteries and rechargeable batteries must be removed prior to the disposal of the product. Depending on the product equipment (partly with optional accessories), single components can also contain batteries and rechargeable batteries. Please observe the disposal symbols on the components.</p>

NOTICE	
	<p><b>Disposal of transport and packaging materials</b></p> <p>The packaging materials are made of recyclable materials and can be disposed of with recyclable materials.</p>



## 9 Disposal

---

Item no. 994536093x-mub-en

Translation of the original instructions

We reserve the right to make technical changes without notice!

Printed in Germany – Copyright by PAW GmbH & Co. KG

PAW GmbH & Co. KG

Böcklerstraße 11

31789 Hameln, Germany

[www.paw.eu](http://www.paw.eu)

Phone: +49-5151-9856-0

Fax: +49-5151-9856-98